

FUJIFILM

# instax mini 41™

INSTANT CAMERA



**User's Guide (Full version)/Safety Precautions**

## Note on handling the instax™ mini instant film pack

**EN** Do not open the back camera cover until all 10 film sheets of the instax™ mini instant film pack have been used. Opening the Film Door will expose any remaining, unused film sheets, rendering the remainder of the film pack unusable.

How to install/replace the required 2 AA batteries (2 AA batteries included)

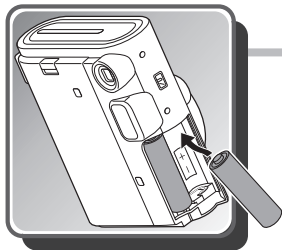

1

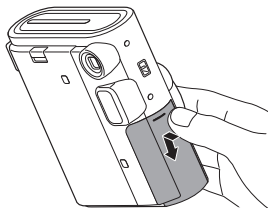

2

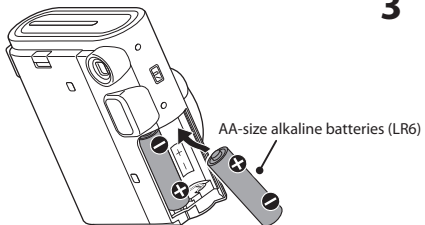

3

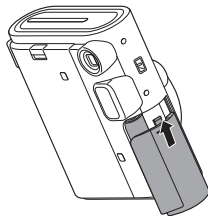

## How to insert the instax™ mini instant film pack



1

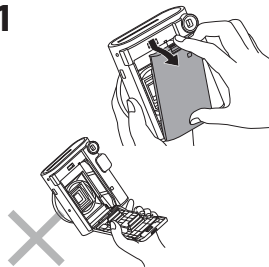

2

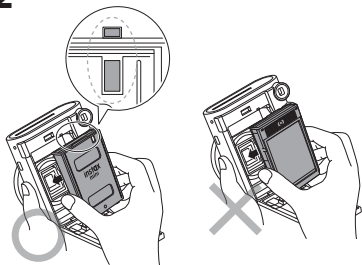

3

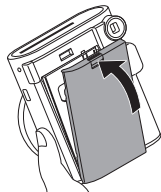

## How to eject the black instax™ mini instant film cover



1

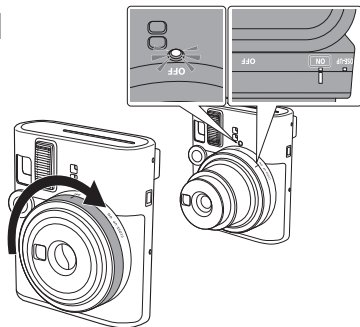

2

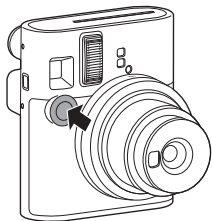

3

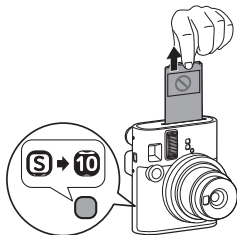

## Before Use

Before using the camera, check to make sure you have the following:

### Supplied Accessories

- Hand Strap (1)
- AA-size Alkaline Batteries (LR6) (2)

## Names of Parts

### Front

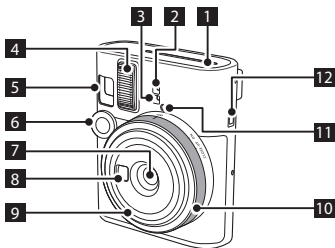

### Back

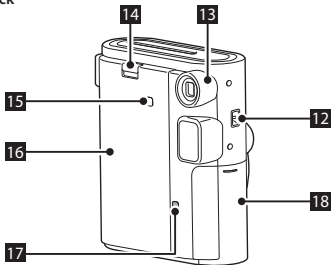

- 1 Film Ejection Slot
- 2 Flash Light Sensor
- 3 Auto Exposure Light Sensor
- 4 Flash
- 5 Viewfinder (Front)
- 6 Shutter Button
- 7 Lens Cover / Lens
- 8 Selfie Mirror
- 9 Lens Barrel
- 10 Lens Ring
- 11 Flash Charging Lamp
- 12 Strap Eyelet
- 13 Viewfinder (Back)
- 14 Film Door Lock
- 15 Film Confirmation Window
- 16 Film Door
- 17 Film Counter
- 18 Battery Cover

## Before Taking Photos

- 1 Load the instax™ mini instant film pack into the camera.**

For details on how to load the film pack, see page 4.



- 2 Turn on the camera by rotating the Lens ring to ON.**

The lens barrel extends and the flash charging lamp blinks and then lights up. (Blinking indicates that the flash is charging.)

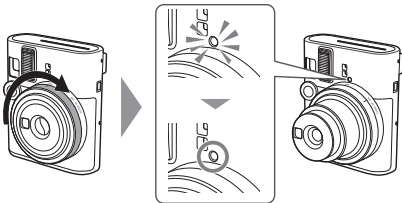

- 3 Press the Shutter button.**

The camera ejects a black film cover. When the sound of the film cover being ejected stops, grasp the edge of the ejected film cover and take the film out.

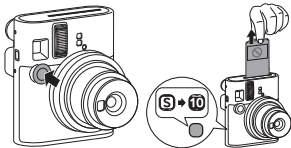

### NOTE:

Do not open the back camera cover until all 10 film sheets of the instax™ mini instant film pack have been used. Opening the Film Door will expose any remaining, unused film sheets, rendering the remainder of the film pack unusable.

The number on the Film counter decreases in numerical order, counting down from "10" with each photo taken. "0" will be displayed when the film is finished and after the last photo has been taken (i.e. the 10th photo has been taken).



## How to Take Photos

- 1 Once the batteries are loaded, turn on the camera by rotating the Lens ring to ON.

The lens barrel extends and the flash charging lamp blinks and then lights up. (Blinking indicates that the flash is charging.)

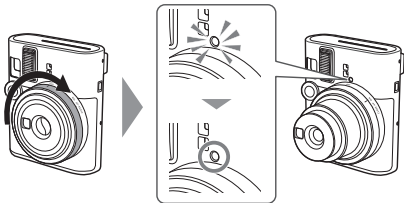

- 2 Hold the camera, look through the Viewfinder (Back) of the camera to frame your desired composition, and press the shutter button.

\* The shutter button cannot be pressed while the flash is charging.



- 3 When the sound of the film being ejected stops, grasp the edge of the ejected film and take the film out.



The film counter decreases in numerical order, counting down from "10" with each photo taken. "0" will be displayed when the film is finished and after the last photo has been taken.

- 4 When you have finished taking photos, turn off the camera by rotating the Lens ring to OFF.

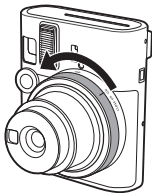

If the camera malfunctions, remove the batteries while the power is on and then reinsert them to reset the camera.

## Taking a Photo in Close-Up Mode

### Taking a close-up

Close-Up Mode allows you to take a close-up photo of your subject.

- 1 Turn the Lens ring to the "CLOSE-UP" position and the lens barrel will pop out automatically. The viewfinder field of view switches to the close-up shooting setting.

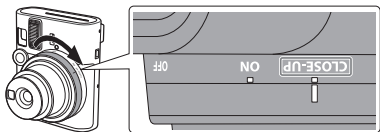

- 2 Hold the camera so that the  $\bigcirc$  mark in the viewfinder is in the center of the subject, then press the shutter button to take a photo.

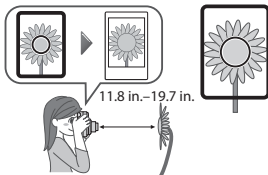

### Taking a picture of yourself

You can also use Close-Up Mode to take selfies. Confirm your composition using the selfie mirror at the front of the lens, then you can take a photo.

- 1 Turn the Lens ring to the "CLOSE-UP" position and the lens barrel will pop out automatically. The viewfinder field of view switches to the close-up shooting setting.
- 2 Hold the camera securely so that your face is roughly 11.8 inches to 19.7 inches (30 cm - 50 cm) away from the end of the lens.

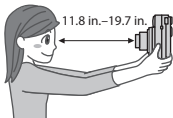

- 3 Confirm the composition using the selfie mirror, then push the shutter button to take the photo.

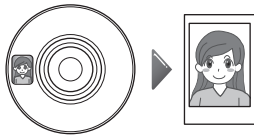

## Removing the instax™ mini Instant Film Pack

The Film counter decreases in numerical order, counting down from "10" with each photo taken. "0" will be displayed when the film is finished and after the last photo has been taken.

When the counter reaches "0", turn off the power and remove the used film pack.

1

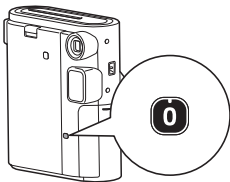

2

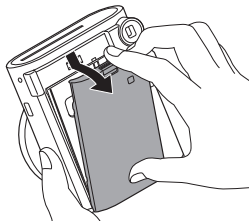

3



## Precautions when Taking Photos

### Precautions when holding the Camera



Correct way to hold



Do not cover the Flash with your finger while taking a photo



Do not cover the Flash light sensor and Auto Exposure Light Sensor with your finger

- Make sure that your finger or the strap does not cover the Flash light sensor, Auto Exposure Light Sensor, Flash, Lens or Film ejection slot. See page 7 to see where these camera features are located on the camera body.
- Hold the camera so that the Flash is at the top when taking a horizontal photo.
- Do not take photos using the flash feature in locations where flash photography is forbidden.
- Do not grasp the lens barrel when holding the camera. The finished photos may be adversely affected.
- When looking through the Viewfinder (Front), ensure that the  mark is visible in the center of your subject.
- Be careful not to touch the Lens or otherwise obstruct the Lens when you press the shutter button.
- **When taking photos in the dark, hold the camera firmly to prevent blurring, as the shutter speed may be slow.**

### Distances for Normal Mode and Close-Up Mode

- In Normal Mode, take a photo at a distance of at least 19.7 inches (0.5 m) from the subject. The effective flash range is up to approximately 7.2 ft (2.2 m).
- Use Close-Up Mode when holding the camera closer than 19.7 inches (0.5 m) from the subject. Close-Up Mode allows you to take photos at a range of 11.8 inches to 19.7 inches (30 to 50 cm) from the subject.

### Flash charging lamp statuses and error solutions

Flash charging lamp status	Description
Lit	Ready to take a photo.
Off	Camera is off.
Slow flashing	The flash is charging. Please wait until the charging lamp lights.
Repeated slow flashing and quick flashing	The battery voltage is low.
Quick flashing	An error has occurred. <ul style="list-style-type: none"><li>• The film is jammed.</li><li>• Incorrect Lens ring position.</li><li>• Other error</li></ul> If this continues, contact the applicable Fujifilm Customer Service/Repair Center.

## Troubleshooting

Main errors	Solution
The battery voltage is low	Replace the batteries with new ones (alkaline batteries).
Film jammed	Do not pull out the film. Remove the batteries and reinsert new batteries (alkaline batteries). It may be possible to eject the film after these steps are taken. If this continues, contact a FUJIFILM authorized dealer for assistance.
Incorrect Lens ring position	Set the Lens ring in the proper position.
Other	The camera may be malfunctioning. Remove and reinsert the batteries while the power is on.

## IMPORTANT SAFETY NOTICE

- Do not use this product and its accessories for a purpose other than taking instant photos.
- This product has been designed with safety in mind, but please read the following safety precautions carefully and then use the product correctly.





### WARNING

This symbol indicates danger, which could result in product damage, injury or death. Follow the instructions indicated to avoid damage to the camera or injury.

### CAUTION

This indicates a matter that may lead to injury or physical damage if ignored or incorrectly handled.

### WARNING

-  Never attempt to take this product apart. You may be injured.
-  Do not touch this product if the inside of it becomes exposed due to dropping, etc. This product has high-voltage circuitry that may cause electric shock.
-  If you notice anything abnormal, such as the camera (batteries) becoming hot, emitting smoke, or making a burning smell, remove the batteries immediately. Fire or burns may occur (be careful not to burn yourself when removing the batteries).
-  Never take flash photographs of people riding bicycles, driving cars, skateboarding, riding a horse and the like. The flash can be startling, distract, frighten animals, and otherwise cause an accident.

- ⚠ If you drop the camera in water or if water or a piece of metal or other foreign object gets inside, remove the batteries immediately. Heat generation or fire may occur.
- ⚠ Do not use this camera in places where there is flammable gas or near open gasoline, benzine, paint thinner or other unstable substances which can give off dangerous vapors. Use in such environments could result in explosion or fire.
- ⚠ Do not disassemble, heat the batteries, throw them in a fire, or put them in an electrical short circuit. The batteries may rupture.
- ⚠ Use only AA (LR6) batteries. Heat generation or fire may occur if other batteries are used.
- ⚠ Keep batteries out of the reach of infants. An infant may accidentally swallow a battery. In the event that a battery is swallowed, seek medical attention immediately.

### CAUTION

- ⚠ If the camera is not functioning correctly, contact the applicable Fujifilm customer service or repair center. To avoid injury, do not attempt to repair this product yourself.
- ⚠ Do not touch any parts within the inside of the Film Door. This may cause injury.
- ⚠ Do not handle this product with wet hands. Electric shock may occur.
- ⚠ Keep the product out of the reach of infants and small children. Injury may occur.
- ⚠ Do not cover or wrap the camera in a cloth or blanket. This can cause heat to build up and distort the casing or cause a fire.
- ⚠ Using a flash too close to a person's eyes may for the short term affect their eyesight. Take care when taking photo of infants and young children.

- ⚠ Make sure that the battery ⊕ and ⊖ polarities are correct. Damage to surrounding area may occur if the camera is damaged or if battery fluid leaks out.
- ⚠ Do not touch moving parts inside the camera. You may be injured.
- ⚠ Do not mix old and new batteries. Do not mix alkaline, standard (carbon-zinc), lithium or rechargeable (ni-cad, ni-mh etc.) batteries.



The "CE" mark certifies that this product satisfies the requirements of the European Union (EU) regarding safety, public health, environment, and consumer protection. ("CE" is the abbreviation of Conformité Européenne.)

- **Legally required regulation compliance displays are located on the inside of the back cover of the camera.**

## ■ Handling of Camera

1. **Do not open the back camera cover until all 10 film sheets of the instax™ mini instant film pack have been used. Opening the Film Door will expose any remaining, unused film sheets, rendering the remainder of the film pack unusable.**
2. The camera is a precision instrument, so do not get it wet, drop it, or subject it to shock. Also, do not place the camera where it will be exposed to sand, dirt or dust particles.
3. Do not use solvent such as thinner or alcohol to wipe off dirt.
4. Any dirt or dust in the film chamber will affect the finish of the print. Do not allow the film chamber to get dirty or dusty.
5. Do not leave the camera in a closed motor vehicle, another hot place, a humid place, on the beach, etc., for a long period of time.
6. Gas containing moth repellent may adversely affect the camera and instax™ instant film. Avoid keeping the camera and instax™ instant film in a chest of drawers, etc. with mothballs.
7. The operating temperature range of this camera is 41°F (+5°C) to 104°F (+40°C).
8. When taking photos, please be careful not to violate the rights of others, such as copyright, image rights, and privacy, or violate public order. Any act that violates the rights of others, or is contrary to public order or morals, or constitutes a nuisance, is subject to legal penalties and claims for damages.
9. This camera is for general household use. It is not suitable for commercial photography and other applications where a large number of prints are used.

10. Before using a commercially available strap, check the strength of the strap. Be especially careful when using a strap for mobile phones and Smartphones because such straps are made for lightweight devices. Use of the provided Hand Strap is recommended.
11. If you are not using your camera for a long period of time, unload the batteries and keep them where they will avoid heat, dust and moisture.
12. Remove soil and dust from the Viewfinder window, etc., with an air blower and by wiping gently with a piece of soft cloth.

## ■ Cautions During Printing



## ■ Handling of instax™ mini Instant Film and Photos

For details on the handling of film and photos, see the instructions written on the FUJIFILM instax™ mini instant film packaging.

1. Keep film in a cool place. In particular, do not leave film in an extremely hot place, such as in a closed motor vehicle, for a long period of time.
2. Do not make a hole in film or tear or cut film. Do not use film that is damaged.
3. Use film as soon as possible after inserting it in the camera.
4. If film has been kept in a place where the temperature is extremely low or high, allow it to become accustomed to a normal temperature before taking pictures.
5. Be sure to use the film before the expiration or "Use Before" date on the instant film package.

- Avoid airport checked luggage inspection and other strong X-ray exposure. Unused film is susceptible to the effect of fogging, etc. We recommend that you carry film onto aircraft in carry-on luggage (check with the relevant airport for more information).
- Avoid exposing instant photos to strong light, and store them in a cool and dry place.
- Do not cut, peel apart or puncture new or newly used instant film. Film contains a small amount of highly caustic paste; paste can remain active up to 10 minutes after instant photo ejects. Be especially careful not to let infants or pets put the film into their mouth. Paste should not come into contact with skin or clothes.
- If you accidentally touch the paste of unused instax™ mini instant film, immediately wash it off with plenty of water. If the paste comes into contact with the eyes or mouth, wash the area and then seek medical attention. The alkalinity of instax™ mini instant film will weaken approximately 10 minutes after the instant photo is ejected from the camera.
- Do not store instant photos in a sealed bag, as this may cause discoloration.
- Do not touch the image during development time.

#### ■ Cautions on Handling of instax™ mini Instant Film and Finished Photos

For details, see the instructions on the FUJIFILM instax™ mini instant film packaging.





**For customers in the USA:****FCC Statement**

This device complies with part 15 of the FCC Rules.

Operation is subject to the following two conditions:

(1) this device may not cause harmful interference, and (2) this device must accept any interference received, including interference that may cause undesired operation.

For more information, access the website below.

<https://instax.com/mini41/>

**CAUTION**

This equipment has been tested and found to comply with the limits for a Class B digital device, pursuant to Part 15 of the FCC Rules.

These limits are designed to provide reasonable protection against harmful interference in a residential installation.

This equipment generates, uses, and can radiate radio frequency energy and, if not installed and used in accordance with the instructions, may cause harmful interference to radio communications.

However, there is no guarantee that interference will not occur in a particular installation.

If this equipment does cause harmful interference to radio or television, which can be determined by turning the product off and on, the user is encouraged to try to correct the interference by one or more of the following measures:

- Reorient or relocate the receiving antenna.
- Increase the separation between the product and receiver.
- Connect the product into an outlet on a circuit different from that to which the receiver is connected.
- Consult the dealer or an experienced radio/TV technician for help.

Changes or modifications not expressly approved by Fujifilm responsible for compliance could void the user's authority to operate the equipment.

**For customers in Canada :****CAN ICES-003 (B)/NMB-003 (B)**

This Class B digital apparatus complies with Canadian ICES-003.

## Notes on Disposing of the Camera

### Proper Disposal – US, Canada and Latin America



Disposal of Electric and Electronic Equipment in Private Households  
Disposal of used Electrical & Electronic Equipment  
(Applicable in the European Union and other European countries with separate collection systems)

This symbol on the product, the full version of the User's Guide, Quick Start Guide, in the limited product warranty, and/or on its packaging indicates that this product shall not be treated as household waste.

Instead it should be taken to an applicable collection point for the recycling of electrical and electronic equipment. By ensuring this product is disposed of correctly, you will help prevent potential negative consequences to the environment and human health, which could otherwise be caused by inappropriate waste handling of this product. The recycling of materials may help to conserve natural resources.

For more detailed information about recycling of this product, please contact your local city recycling office, your household waste disposal service or the authorized Fujifilm dealer from which you purchased the product.

For proper disposal in the United States at product end-of-life, please contact 1-800-800-3854 Option #1 INSTAX.

For proper disposal in Canada at product-end-of-life, please contact 1-800-461-0416.

For proper disposal in Latin America at product end-of-life, please contact your local FUJIFILM distributor or dealer for disposal instructions.

## Specifications

Film Used	FUJIFILM instax™ mini instant film (sold separately)
Photo Picture Size	2.4 in. x 1.8 in. (62 mm x 46 mm)
Lens	2 components, 2 elements, f = 60 mm, 1:12.7
Viewfinder	Real image finder, 0.37x, with target spot Features parallax correction function for Close-Up Mode
Shooting Range	11.8 in. (0.3 m) and beyond (use Close-Up Mode for 11.8 in. (0.3 m) to 19.7 in. (0.5 m))
Shutter	Programmed electronic shutter 1/2 to 1/250 sec. Slow synchro for low light
Exposure Control	Automatic, Lv 5.0 to 14.5 (ISO 800)
Film Ejection	Automatic
Film Developing Time	Approx. 90 seconds (varies depending on the ambient temperature)
Flash	Constant firing flash (automatic light adjustment), recycle time: 7 seconds or less (when using new batteries), effective flash range: 11.8 in. (0.3 m) to 7.2 ft (2.2 m)

Power Supply	Two AA-size alkaline batteries (LR6), capacity: approx. 10 instax™ mini instant film packs of 10 exposures each (100 exposures) per set of new batteries (depends on usage conditions) * The supplied batteries are for initial use. When they run out, replace them with new ones (Two AA-size alkaline batteries LR6). * Manganese batteries are not compatible.
Auto Power Off Time	After 5 minutes
Other	Includes film counter and film pack confirmation window
Dimensions (W x H x D)	4.11 in. x 4.82 in. x 2.66 in. (104.5 mm x 122.5 mm x 67.5 mm)
Weight	0.76 lbs / 345 g (without batteries and instant film loaded, and without strap attached)

**Information for Fujifilm in the United States**

FUJIFILM North America Corp.  
200 Summit Lake Drive  
Valhalla, New York 10595, USA  
1-800-800-3854 Option #1 INSTAX

**Information for Fujifilm in Canada**

FUJIFILM Canada Inc.  
600 Suffolk Court  
Mississauga, Ontario L5R 4G4, Canada  
1-800-461-0416

*FUJIFILM*, *instax*, and *instax mini 41* are trademarks of FUJIFILM Corporation and its affiliates.

© 2025 FUJIFILM Corporation. All rights reserved.

[ **en** ] If you have any inquiries about this product, please contact the applicable FUJIFILM customer service/repair center, or access the website below.

[ **fr** ] Pour toute question concernant ce produit, veuillez contacter le centre de service client/réparation FUJIFILM approprié ou visiter le site web ci-dessous.

[ **es** ] Si usted tiene alguna pregunta sobre este producto, póngase en contacto con el centro de atención al cliente/reparación de FUJIFILM correspondiente o acceda al sitio web siguiente.

*<https://www.fujifilm.com/>*

# FUJIFILM

---

## FUJIFILM Corporation

7-3, AKASAKA 9-CHOME, MINATO-KU, TOKYO 107-0052, JAPAN/JAPON