

FUJIFILM

instax WIDE Evo™

HYBRID INSTANT CAMERA
[INSTANT PRINT + DIGITAL TECHNOLOGIES]

User's Guide (Full Version)



- Depending on the firmware version, the camera's functions and screens may differ from those described.
- There are two methods to upgrade the firmware. For details, refer to [FIRMWARE UPGRADE]. (p. 29)

Table of Contents

Introduction to the Camera.....	4	Storage Location.....	19
Before Use.....	4	When Micro SD Memory Card is Not Inserted	19
About the instax WIDE Evo™ Hybrid Instant Camera ...	4	When Micro SD Memory Card is Inserted	19
Main Features.....	4	Maximum Number of Images/Resolution	19
Functions Available with the free instax WIDE		Advanced Operation – Shooting	20
Evo™ Smartphone App.....	4	Various Shots – Direct Menu	20
Attaching the Shoulder Strap	5	Changing the Brightness of the Image	20
Part Names.....	5	Using the Self Timer to Take Photos.....	20
LCD Monitor Display	7	Taking Photos with the Flash	21
Using the Select and Menu/Ok Buttons	8	Matching the Light Source When Taking Photos ...	21
Using a Micro SD Memory Card (Sold Separately)	8	Taking Macro Photos	22
Inserting a Micro SD Memory Card	9	Easy Focusing	22
Removing a Micro SD Memory Card	9	Photography with Effects	23
Charging the Battery	10	Adding Effects to Your Photos	23
Charging Status Indication When the Camera is		Selecting Lens Effects	23
Turned Off	10	Adjusting the Degree of Lens Effect	23
Inserting the instax™ WIDE Instant Film Pack (Sold		Selecting a Film Effect	24
Separately).....	10	Selecting a Film Style.....	24
Power On/Off.....	11	Effect Combinations.....	25
How to Check the Battery Level.....	11	Saving an Effect Combination.....	25
Setting up the Language and Date/Time	12	Using your Saved Effect Combinations	25
Basic Operations – Shooting/Playback/Print	13	Reset Lens Effects, Film Effects and Film Styles	26
Basic Shooting	13	Image Adjustment During Playback and Printing	27
Taking Photos.....	13	Various Playback – Direct Menu	27
Shooting in Wide-Angle Mode.....	14	Rotating and Adjusting the Position of the	
Taking a Photo of Yourself (Selfie).....	15	Image	27
Using AF/AE Lock to Take Photos	15	Enlarging the Image.....	27
Viewing Shooting Information	15	Selecting Image Quality	28
Playing Back the Images You Have Taken	16	Adjusting the Brightness of the Printed Image	28
Deleting Images.....	16	Settings Menu	29
Single-Frame Display.....	16	Operations and Items in the Settings Menu	29
4/9-Frames Display.....	16	free instax WIDE Evo™ Smartphone App	31
About the Remaining Film Sheets Display	17	Smartphone App Functions	31
Viewing Shooting Information	17	Installing the free instax WIDE Evo™ Smartphone	
Printing Images.....	18	App.....	31
Removing the instax™ WIDE Instant Film Pack.....	18	When Disposing of the Camera	32
Stored Images	19	Removing the Battery at End of Life	32
		Other Information	33
		Specifications	33

Troubleshooting34

IMPORTANT SAFETY NOTICE.....35

 Camera Care35

 Bluetooth® Devices: Cautions36

Preparing Camera for Use

Please peel off the protective cover before use.

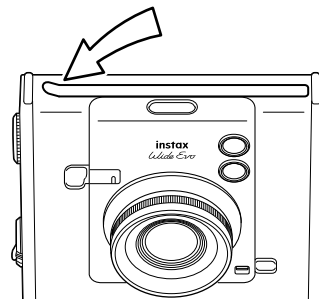

Note When Handling the instax™ WIDE Instant Film Pack (Sold Separately)

Do not open the back camera cover until all 10 film sheets of the instax™ WIDE instant film pack (sold separately) have been used. Opening the Film Door will expose any remaining, unused film sheets, rendering the remainder of the film pack unusable.

Introduction to the Camera

Before Use

Before using the camera, check to make sure you have the following.

Supplied Accessories

- USB Type C cable (BO38A34001) (1)

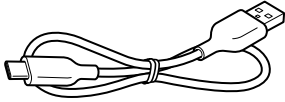

- Shoulder Strap (1)

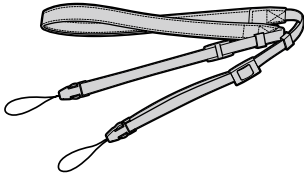

- Lens cap (1)



- Use the Shoulder Strap over your shoulder, not around your neck.
- Make sure the Shoulder Strap does not hang over the Film Ejection Slot.
- The battery has not been fully charged at the factory. Be sure to fully charge the battery using the supplied USB Type C cable.
- The included USB Type C cable should only be used for charging the camera.

Read 'IMPORTANT SAFETY NOTICE' (p. 35) for safety information.

About the instax WIDE Evo™ Hybrid Instant Camera

Main Features

- Express yourself creatively with 10 lens and 10 film effects, a lens effect degree adjustment and 6 film styles.
- You can take wide-angle photos with the widest lens in the instax™ device family.
- You can take photos while looking at the LCD Monitor and save them to either the main unit or a Micro SD Memory Card (sold separately). Approximately 45 photos can be stored in the camera's internal memory.
- You can select and print your images onto instax™ WIDE instant film (sold separately).
- A classic design with an authentic feel.
- Analog-style operation with a Lens Dial, Film Dial, Degree Control Dial, and Print Crank.
- Features a Selfie Mirror for easy selfies.

Functions Available with the free instax WIDE Evo™ Smartphone App

Download of the free instax WIDE Evo™ App is required for the below features. For instructions on how to download the App, please see the product box or page 31.

● Direct Print

Transfer a photo from your Smartphone to the camera, and print it with the camera using the instax™ Direct Print feature on the App. Before printing the photo, you can use the instax WIDE Evo™ App to rotate it, enlarge it or reduce its size.

● Remote Shooting

Control the camera with your Smartphone for remote shooting of photos.

● Save Printed Images

You can transfer photos you had printed with the camera to the instax WIDE Evo™ App. You can also add instax™ frames to your images and save them on your Smartphone.

● Discover Feed

The Discover Feed section in the App allows you to explore other users' images that were taken with the instax WIDE Evo™ hybrid instant camera in addition to displaying your own images. You can also check out the effects and settings that were used.

● Add to Favorites

You can easily save the film effect settings of works you have printed or that others have used (where such photos are posted on the Discover Feed) to your camera favorites for future use.

Introduction to the Camera

Attaching the Shoulder Strap

Follow the steps below to attach the Shoulder Strap to the camera body. You need to detach the ends from the Shoulder Strap body before passing it through the Shoulder Strap Hook on the camera.

- 1** Insert one end of the Shoulder Strap through the Shoulder Strap Hook on the camera.

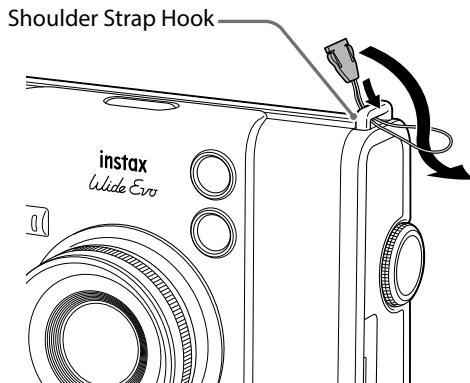

- 2** Attach the Shoulder Strap Body to the end of the Shoulder Strap.

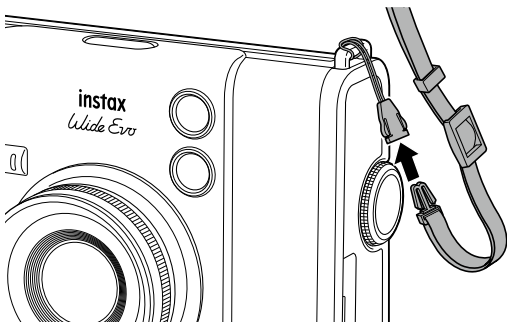

- 3** Loop the second Shoulder Strap End into the second Shoulder Strap Hook and then attach the Shoulder Strap Body to the second Shoulder Strap End in the same manner.

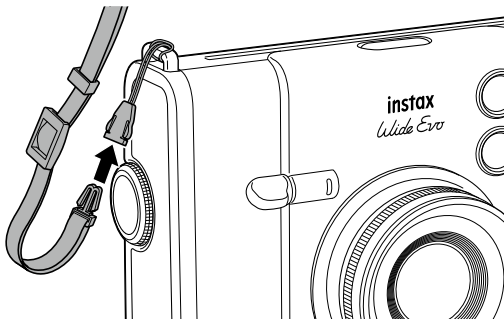

Part Names

Front

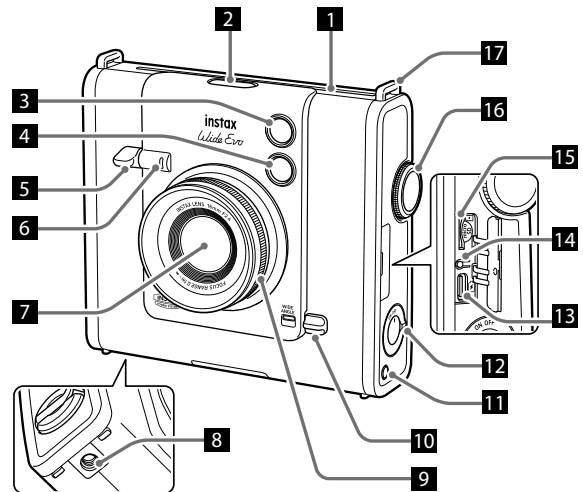

Rear

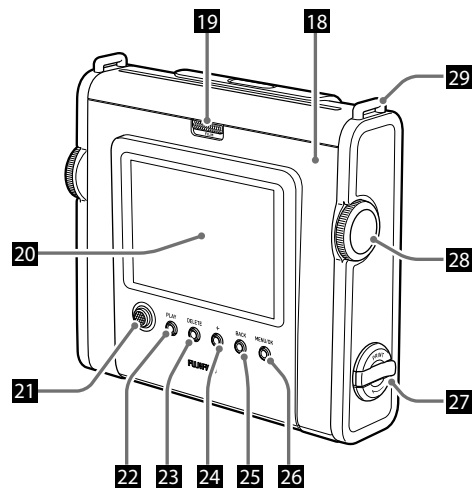

Introduction to the Camera

- 1** Film Ejection Slot
This is the instax™ WIDE instant film ejection slot. instax™ WIDE instant film pack required (sold separately).
- 2** Film Style Button
Switches between 6 creative film styles to be applied to your instax™ WIDE photo.
- 3** Flash
The Flash operates depending on the Camera setting. You can also set the Flash to not operate.
- 4** Selfie Mirror
You can see yourself in the Selfie Mirror to check the composition of the photo, and ensure you are in the shot.
- 5** Shutter Lever
See page 13 for shutter functionality.
If the camera is in Playback Mode, press this Shutter Lever to switch back to Shooting Mode.
- 6** Self Timer Lamp / Charging Lamp
The Self Timer Lamp / Charging Lamp blinks when you take a photo with the self timer. It also lights up during charging and turns off when charging is complete.
- 7** Lens
- 8** Tripod Mount
Securely attach your tripod into the Tripod Mount (tripod sold separately).
- 9** Degree Control Dial
Adjusts the degree of lens effect (making the selected lens effect appear brighter or more intense).
- 10** Wide Angle Switch
Sliding the switch upwards shoots in Wide-Angle Mode.
- 11** Effect Reset Button
Resets the selected lens effect, film effect, and film style to default.
- 12** Power Switch
Turns the power on or off.
- 13** USB Type C Port
This is the USB port for charging the camera. A USB Type C charging cable has been supplied with the camera. The USB port cannot be used for data transfer.
- 14** Reset Button
If the camera is not operating properly, press this button to force the camera to turn off. After pressing the Reset Button, turn the Power Switch off and then on again to start the camera. **Do not use the Reset Button while the camera is operating normally. Doing so may cause the photo data to be erased.**
- 15** Micro SD Memory Card Slot
Insert a Micro SD Memory Card (sold separately) into the camera.
- 16** Lens Dial
Switches between 10 lens effects.
- 17** Shoulder Strap Hook (one of two)
Attach the Shoulder Strap to the Shoulder Strap Hooks as indicated on page 5.
- 18** Film Door
When loading/unloading an instax™ WIDE instant film pack (sold separately), slide the Film Door Lock to unlock the Film Door and lift it open. Do not open the Film Door until you have used up all the film.
- 19** Film Door Lock
Slide the Film Door Lock to unlock the Film Door so that it can be lifted open.
- 20** LCD Monitor
You can see the subject to be photographed during shooting and check photos you have taken on the LCD Monitor. You can also view and select the menu items on the LCD Monitor.
- 21** Select Button
Use the Select Button to select menu items and to use the functions displayed on the LCD Monitor.
- 22** Play Button
Press the Play Button to display the photos you have taken on the LCD Monitor. When in Shooting Mode, this button is also used to switch to Playback Mode.
- 23** Delete Button
Deletes the image displayed on the LCD Monitor.
- 24** +(Function) Button
Press the +(Function) Button in Shooting Mode to check the current effect on the LCD Monitor. You can also save and use your favorite effect combinations.
- 25** Back Button
Press the Back Button to return to the previous screen.
- 26** Menu/Ok Button
During shooting or playback, press the Menu/Ok Button to display the menu on the LCD Monitor. This button is also used to select menu items.
- 27** Print Crank
Prints the image displayed on the LCD Monitor.
- 28** Film Dial
Switches between 10 film effects.
- 29** Shoulder Strap Hook (one of two)
Attach the Shoulder Strap to the Shoulder Strap Hooks as indicated on page 5.

Introduction to the Camera

LCD Monitor Display

When the camera is turned on, the Shooting screen appears on the LCD Monitor. Each time you press the Play Button, the screen switches between the Shooting screen and the Playback screen. Pressing the Menu/Ok button displays the **Direct Menu**. The Direct Menu is a menu for making image adjustments during shooting/playback/printing.

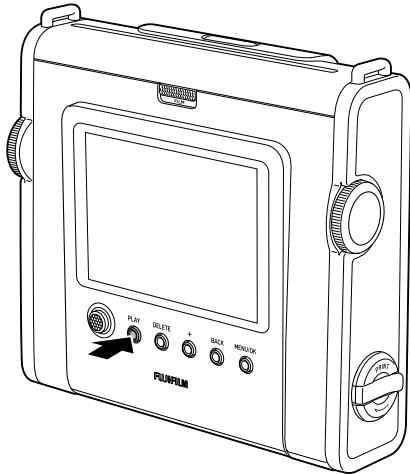

- When the Playback screen is displayed, pressing the Shutter Lever switches the screen to the Shooting screen.

Shooting screen

The subject can be checked on the LCD Monitor. This mode is called the **Shooting Mode**.

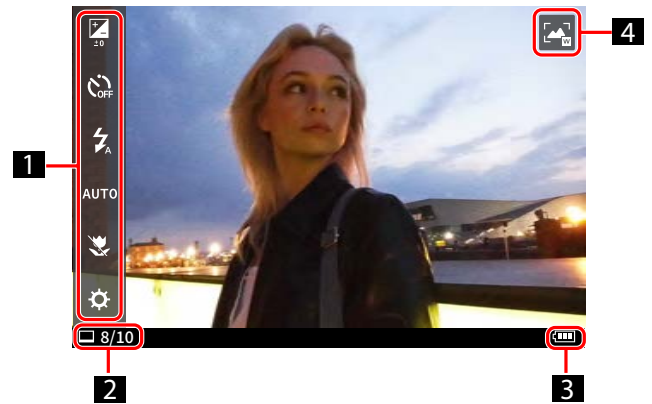

Playback screen

When in Shooting Mode, pressing the Play Button displays the captured image. This mode is called **Playback Mode**.

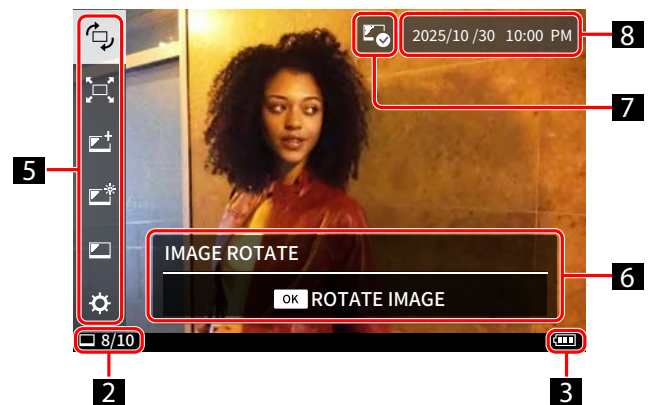

- 1** Direct menu (in Shooting Mode)
When the Menu/Ok button is pressed, it appears on the left side of the LCD Monitor. You can set the self timer, flash, brightness adjustment, and other shooting settings.
- 2** Number of film sheets available for shooting
- 3** Battery level
- 4** Wide-Angle Mode
- 5** Direct menu (in Playback Mode)
When the Menu/Ok button is pressed, it appears on the left side of the LCD Monitor. Image position, size, quality, brightness, and other image adjustments can be made during playback/printing.
- 6** Operation guide
The Direct menu operation guide appears in this area.
- 7** Pre-printed mark
This mark appears on images you have printed previously.
- 8** Shooting date and time

Introduction to the Camera

Using the Select and Menu/Ok Buttons

■ Select Button

Selects a menu item.

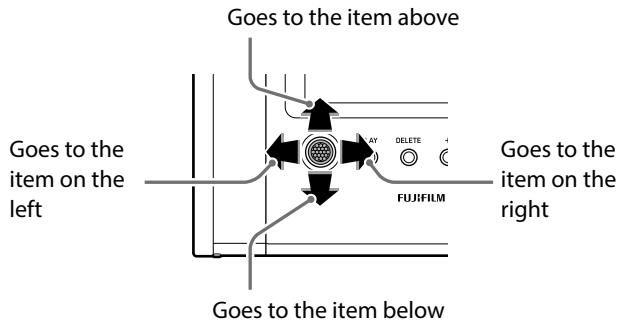

■ Menu/Ok Button

Determines menu item or selection.

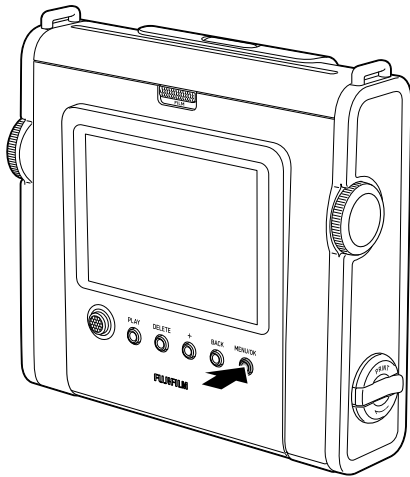

Using a Micro SD Memory Card (Sold Separately)

The camera's internal memory can store about 45 still images, but you can store additional images by using a Micro SD Memory Card (sold separately).

Precautions Regarding Micro SD Memory Cards

- This camera is compatible with Micro SD Memory Cards and Micro SDHC Memory Cards. Using other types of Memory Cards may cause damage to the camera.
- Micro SD Memory Cards are small and can be accidentally swallowed by infants. Keep them out of the reach of infants. In the unlikely event that an infant swallows a Micro SD Memory Card, consult a physician immediately.
- **Do not turn off the camera or remove the Micro SD Memory Card during formatting or while recording/deleting data. The Micro SD Memory Card may be damaged.**
- Do not use or store Micro SD Memory Cards in an environment that is prone to strong static electricity or electrical noise.
- Inserting a Micro SD Memory Card charged with static electricity into the camera may cause the camera to malfunction. If this happens, turn the camera off and then on again.
- Do not carry a Micro SD Memory Card in the pocket of your pants. A strong force may be applied when you sit down, which may cause the Micro SD Memory Card to break.
- The Micro SD Memory Card may become hot to the touch after prolonged use, but this is not a fault or a cause for concern.
- Do not put any labels on Micro SD Memory Cards. If the label comes off, it may cause the camera to malfunction.

Precautions Regarding Using a Micro SD Memory Card on a PC

- Always format an unused Micro SD Memory Card or a Micro SD Memory Card that has been used on a PC or other device before using it in the camera.
- When a Micro SD Memory Card is formatted in the camera and used for shooting and recording, folders are automatically created. Do not use your PC to rename or delete folders or files on the Micro SD Memory Card. Doing so may make the Micro SD Memory Card in the camera unusable.
- Do not use your PC to delete images on the Micro SD Memory Card. Always use the camera.
- If you want to edit an image file, copy or move the image file to a hard disk or similar device, and then edit the copied or moved image file.

Introduction to the Camera

Inserting a Micro SD Memory Card

- 1 Open the Micro SD Memory Card Slot Cover.

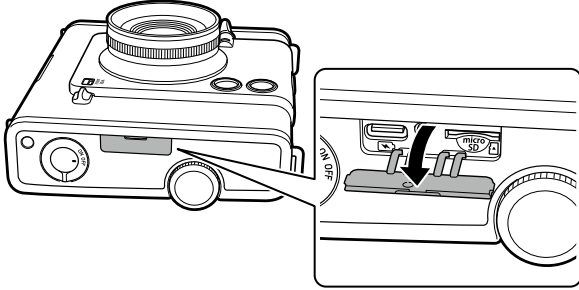

- 2 Insert the Micro SD Memory Card all the way in the correct orientation as shown until you hear a "click".

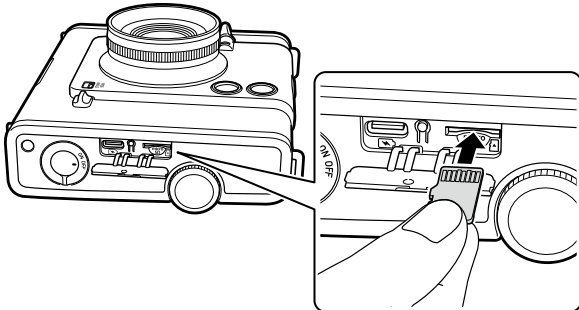

- 3 Close the Micro SD Memory Card Slot Cover.

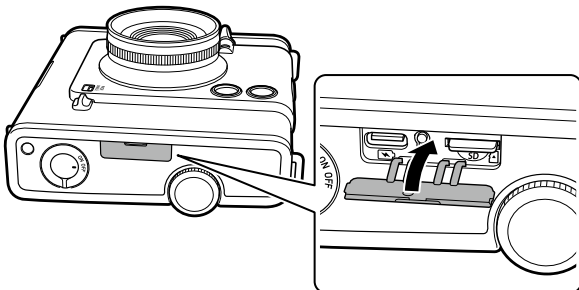

Removing a Micro SD Memory Card

To remove a Micro SD Memory Card, press it in with your finger, then gently release the pressure on the card to eject from the Micro SD Memory Card Slot.

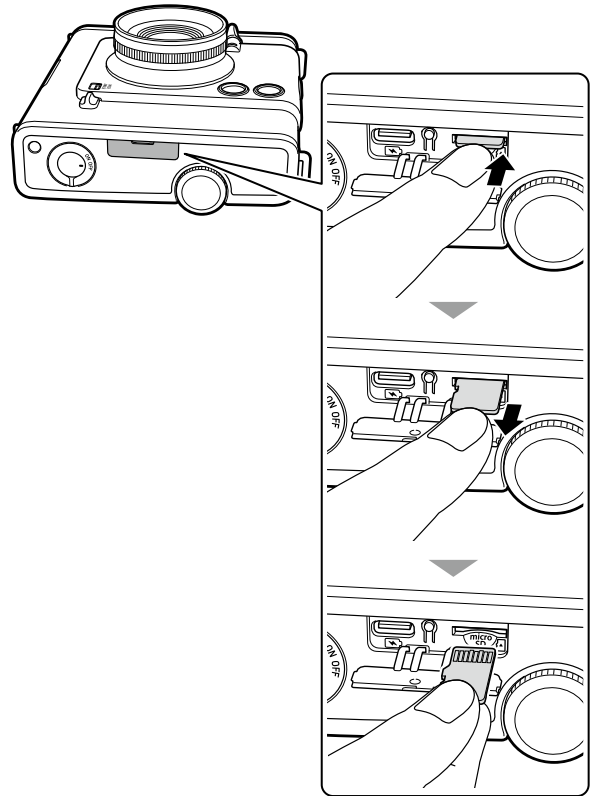

If you suddenly release your finger while removing the Micro SD Memory Card, the card may pop out. Release your finger gently.

NOTE:

The instax WIDE Evo™ hybrid instant camera has limited internal storage of roughly 45 images. Micro SD Memory Card (sold separately) is required for further image storage.

Introduction to the Camera

Charging the Battery

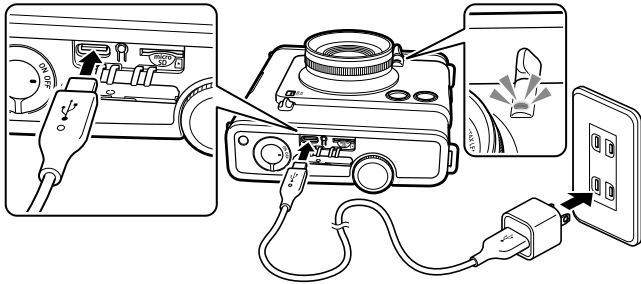

Charge the camera using the supplied USB Type C cable in a USB outlet, or attach the USB Type C cable to a USB AC adapter (adapter sold separately) and charge in an electric power outlet.

- Charging time is approximately 2 to 3 hours.
- The power delivered by the charger must be between min 1.3 Watts required by the radio equipment, and max 2.5 Watts in order to achieve the maximum charging speed.

Charging Status Indication When the Camera is Turned Off

While charging	Self Timer / Charging Lamp lights up.
Charging finished	Self Timer / Charging Lamp goes off.
Charging error	Self Timer / Charging Lamp flashes.

Charging from a PC:

- Connect the camera and PC using the supplied USB Type C cable. Do not connect via a USB hub or keyboard.
- If the PC goes into sleep mode while charging, charging will be paused. To continue charging, exit sleep mode and then reconnect the USB Type C cable.
- Depending on your PC's specifications, settings, or condition, it may not be possible to charge the camera battery from your PC.

Notes

- The battery is not fully charged at the factory, be sure to fully charge the battery before using the camera.
- For notes about the battery, see 'Camera Care' (p. 35)

Inserting the instax™ WIDE Instant Film Pack (Sold Separately)

Note

Do not open the back camera cover until all 10 film sheets of the instax™ WIDE instant film pack (sold separately) have been used. Opening the Film Door will expose any remaining, unused film sheets, rendering the remainder of the film pack unusable.

- When you load the film pack, never press the two rectangular holes on the back of the film pack.
- Never use a film pack beyond its shelf life; otherwise, it may damage the camera.

Use FUJIFILM instax™ WIDE instant film only. instax™ SQUARE film and instax™ mini film cannot be used.

Notes on the film pack

- Each FUJIFILM instax™ WIDE film pack contains a black film protective cover and 10 film sheets.
- Do not remove the film pack from its inner foil packaging until you are ready to load the film into the camera.
- The black film protective cover is ejected automatically when the Film Door is closed.

For details, refer to the instructions and warnings on FUJIFILM instax™ WIDE instant film packaging (sold separately).

1 Slide the Film Door Lock and open the Film Door.

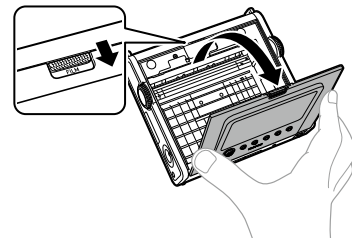

2 Insert an instax™ WIDE instant film pack (sold separately) by aligning the yellow marks.

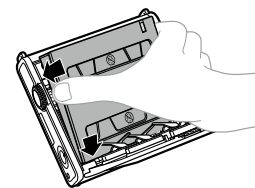

Note

Be sure to align the yellow marks on the camera and on the film pack.

3 Close the Film Door.

Push the Film Door in until it locks.

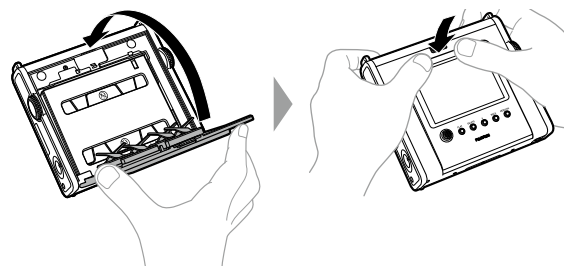

Introduction to the Camera

- 4 Remove the black protective film cover that is ejected automatically.

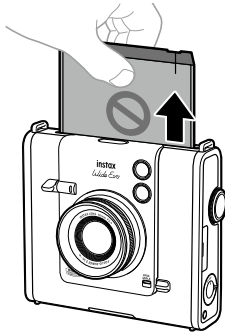

Power On/Off

To turn the camera on, turn the Power Switch clockwise.

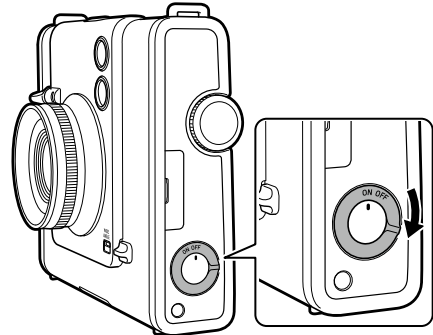

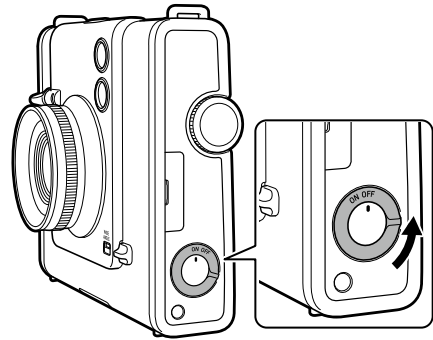

To turn the camera off, turn the Power Switch counterclockwise.



- If you do not operate the camera for 2 minutes, it will automatically turn off. You can change this default setting to turn off the power in 5 minutes or leave the power on, using the Settings menu of the camera. If the camera turns off automatically, turn the Power Switch off and then on again to turn it on.

How to Check the Battery Level

The battery level is displayed at the bottom of the LCD Monitor.

Display	Remaining battery charge
	Sufficient battery charge remaining.
	Less than half of battery charge remaining. Recharging the battery is recommended.
	Low battery charge. Please recharge the battery as soon as possible.

- When the battery is depleted, an icon () will appear in the middle of the LCD Monitor and the power will turn off.

Introduction to the Camera

Setting up the Language and Date/Time

When you turn on the camera for the first time after purchase, you will be automatically prompted to set up the language, date and time.

This setting can be set at a later time. If you want to set or re-set it later, set it from [言語/LANG.] and [DATE/TIME] in the Settings menu.

1 Turn on the power.

- When you turn on the camera for the first time after purchase, the language setting screen will appear.

2 Move the Select Button up or down to select the language you want to use, and then press the Menu/Ok Button.

- [ENGLISH] is selected by default.



- Press and hold the Select Button up or down to move to the next page.



3 Move the Select Button up or down to set the year, month and date depending on your order of preference, and then press the Menu/Ok Button.

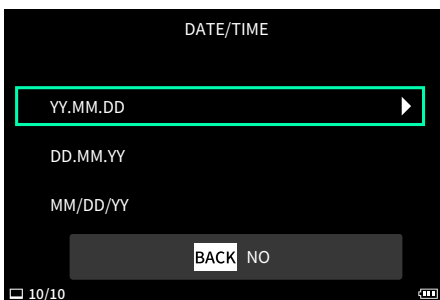

4 Set the year, month, day, hour, and minute, and then press the Menu/Ok Button.

Move the Select Button to left or right to select the item to be set (year, month, day, hour, minute) and then move the Select Button up or down to select the number to be set.

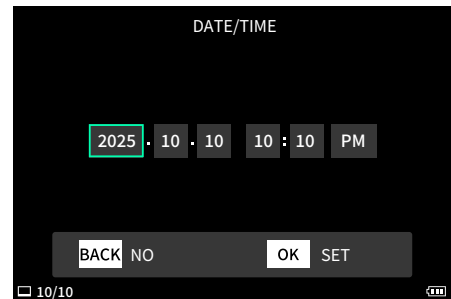

5 Press the Menu/Ok Button.

The language and date/time settings are completed.

Basic Operations – Shooting/Playback/Print

Basic Shooting

Taking Photos

This section gives instructions on how to take photos.

- 1 Turn on the power.
- 2 Hold the camera.
- 3 Select your desired effect as required.

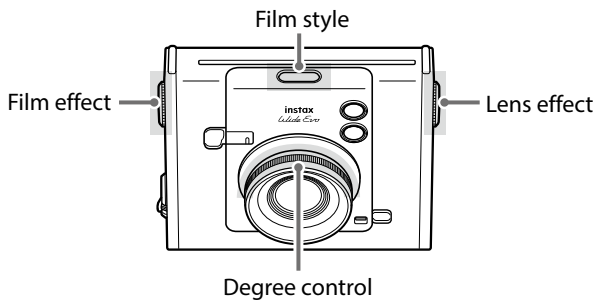

For details on each effect, see 'Photography with Effects' (p. 23).

- 4 Compose the photo.
Move the Select Button up or down to adjust the composition. Move the Select Button up to take a larger image of a distant subject, or move the Select Button down to take a larger area.

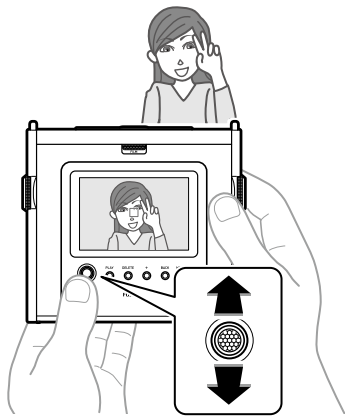

• The zoom function cannot be used in Wide-Angle Mode.

- 5 Press the Shutter Lever halfway to focus on the subject.

When the subject is in focus



A beep is heard and a green AF frame appears on the LCD Monitor.

When [FACE DETECTION] is enabled, a green AF frame appears over the face of the person when the camera recognizes their face. See 'Easy Focusing!' (p. 22)

When the subject is not in focus



A red AF frame appears on the LCD Monitor. Change the composition or use AF/AE lock. See 'Using AF/AE Lock to Take Photos!' (p. 15)

- 6 Fully press the Shutter Lever all the way down.

The shutter is released and the photo is taken.

When a Micro SD Memory Card is inserted, the photos are stored on the Micro SD Memory Card; when a Micro SD Memory Card is not inserted, photos are stored in the camera's internal memory. An internal storage limitation of roughly 45 images applies unless Micro SD Memory Card is inserted.

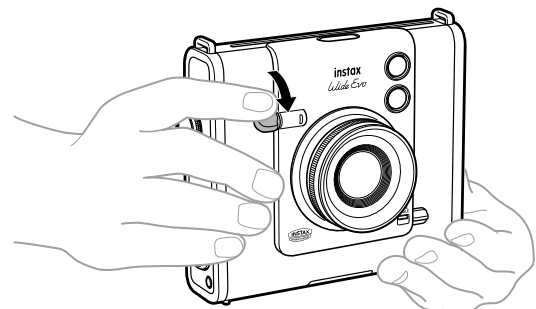

• See 'Printing Images' for instructions on how to print photos you have taken. (p. 18)

Basic Operations – Shooting/Playback/Print

- When taking a photo, hold your arms tightly against your body and hold the camera firmly with both hands.
- Be careful not to touch the camera Lens when you press the Shutter Lever.
- When fully pressing the Shutter Lever, press it gently to prevent the camera from moving and causing the photo to blur.
- Be careful not to let your fingers or the Shoulder Strap cover the Flash or Lens.
- In dark or backlit conditions, the Flash may fire when the Shutter Lever is pressed fully. You can change the Flash settings to prevent the Flash from firing. (p. 21)

Precautions regarding the internal memory

- If the internal memory is at capacity with approximately 45 images, the shutter will not release and you will not be able to take photos. Delete images or use a Micro SD Memory Card (sold separately).
- If the camera malfunctions, images in the internal memory can become damaged or be lost.
- We recommend that you copy important images to another media for backup.
- If you send the camera in for repair, we cannot guarantee the data in the internal memory.
- When the camera is repaired, we may need to check the data in the internal memory.

Shooting in Wide-Angle Mode

To shoot in Wide-Angle Mode, slide the Wide Angle Switch upwards.

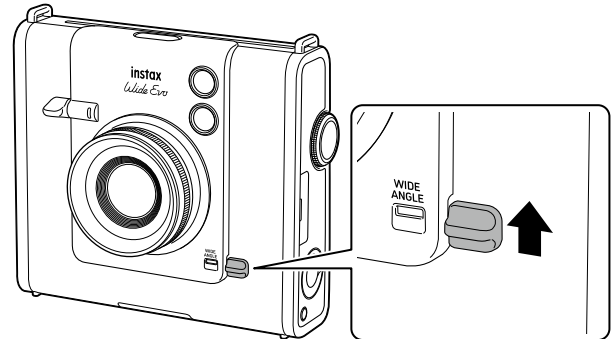

Normal Mode



Wide-Angle Mode

Basic Operations – Shooting/Playback/Print

Taking a Photo of Yourself (Selfie)

You can use the Selfie Mirror to take photos of yourself.

- 1 Hold the camera securely so that your face is roughly 11.8 inches to 19.7 inches (30 cm - 50 cm) away from the end of the Lens.**
 - When taking photos in the dark, hold the camera firmly to prevent blurring.

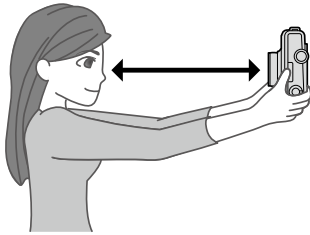

- 2 Confirm the composition using the Selfie Mirror, then press the Shutter Lever fully to take a photo.**

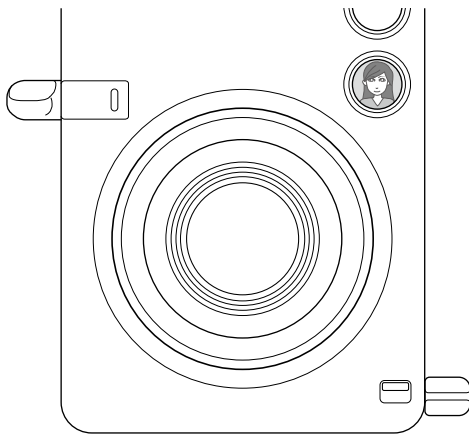

- Do not stare at the Flash when taking photos. Staring at the Flash when taking photos can temporarily affect your eyesight.

Using AF/AE Lock to Take Photos

When taking a photo, pressing and holding the Shutter Lever halfway to lock the focus is called "AF lock," and pressing and holding the Shutter Lever to lock the brightness is called "AE lock." This is useful when you want to take a photo where the subject is not in the center of the screen.

- 1 Press the Shutter Lever halfway to bring the subject into focus.**
Press the Shutter Lever halfway to lock AF or AE.
- 2 Press and hold the Shutter Lever halfway to change the composition.**
- 3 Press the Shutter Lever fully to take the photo.**

It is recommended that you use AE/AF lock when taking photos of the following objects, as they may be difficult to focus on.

- Shiny objects, such as mirrors and car bodies
- Subjects that are moving at high speed
- Subjects on the other side of glass
- Dark objects, such as hair or fur, that absorb light rather than reflect it
- Insubstantial objects such as smoke or flames
- Subjects with little difference between light and dark (for example, a person wearing clothes the same color as the background)
- When there is a large contrast difference in the AF frame and the subject is in that area (for example, a subject in front of a high-contrast background)

Viewing Shooting Information

In Shooting Mode, pressing the Back Button displays certain date, storage and effect information on the LCD Monitor (see sample display below). To return to the Shooting screen, press the Back Button again.

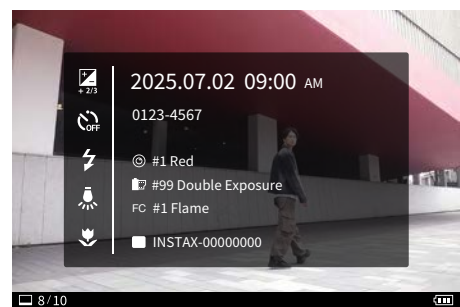

When a Micro SD Memory Card is inserted,  is displayed on the information display screen.

Basic Operations – Shooting/Playback/Print

Playing Back the Images You Have Taken

You can play back the images you have taken on the LCD Monitor.

- 1 Turn on the power.**
- 2 Press the Play Button.**
The last photo you took is displayed.
- 3 Move the Select Button left or right to select the image you want to view.**
 - Press the Shutter Lever fully down or press the Play Button to return to the Shooting screen.

■ Changing the Number of Frames Displayed

When the Playback screen is displayed, rotate the Degree Control Dial to change the number of frames displayed.

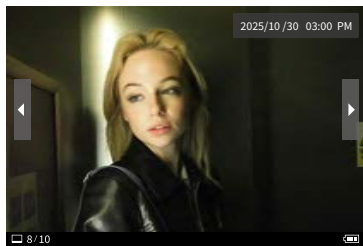
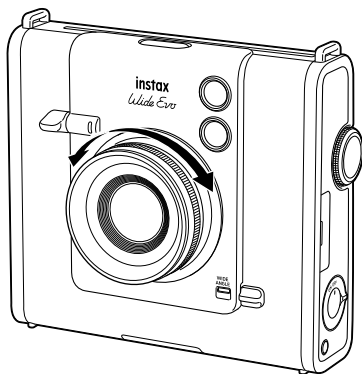

Single-frame display

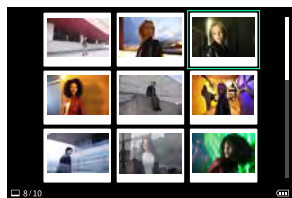

9-frame display

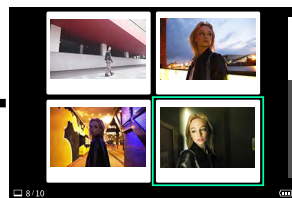

4-frame display

Deleting Images

You can delete unwanted images. You can also delete several images at once.

Single-Frame Display

- 1 Move the Select Button left or right to select the image to be deleted.**
- 2 Press the Delete Button.**
The delete menu appears.

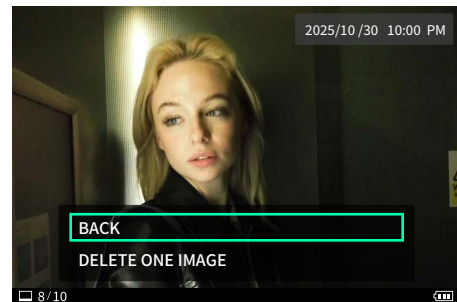

- 3 Move the Select Button up or down to select [DELETE ONE IMAGE] and press the Menu/Ok Button.**
- 4 Press the Menu/Ok Button.**
The selected image is deleted.
 - To cancel deletion, press the Back Button.

4/9-Frames Display

- 1 Move the Select Button up, down, left or right to select the image you want to delete.**

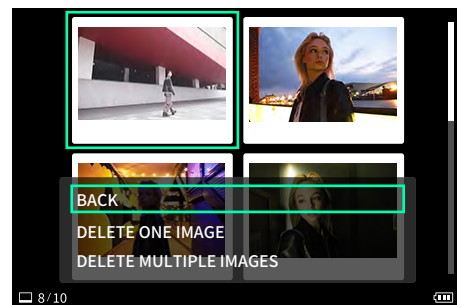

- 2 Press the Delete Button.**
The delete menu appears.
- 3 Move the Select Button up or down to select [DELETE ONE IMAGE] or [DELETE MULTIPLE IMAGES] and press the Menu/Ok Button.**

Basic Operations – Shooting/Playback/Print

- 4** When [DELETE MULTIPLE IMAGES] is selected, move the Select Button up, down, left or right to select the images to be deleted, and press the Menu/Ok Button.

A ✓ mark appears on the selected images.

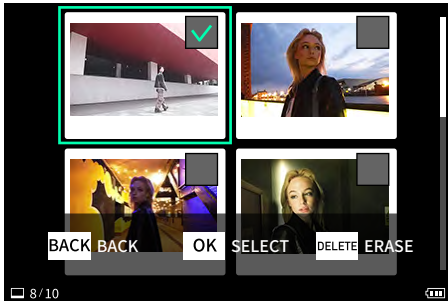

- 5** When you have selected all the images to be deleted, press the Delete Button.

The selected images will be deleted.

- To cancel deletion, press the Back Button.

About the Remaining Film Sheets Display

The number of remaining film sheets is indicated at the bottom of the screen.

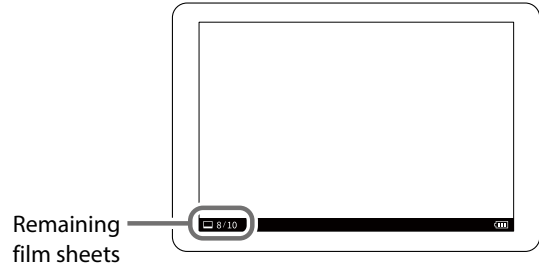

- For details on the handling of film, see the instructions on the FUJIFILM instax™ WIDE instant film packaging. Also see pages 3, 10-11, 18.
- See page 18 for instructions on how to remove the instax™ WIDE instant film pack from the camera.

Viewing Shooting Information

In Playback Mode, pressing the Back Button displays certain date, storage and effect information on the LCD Monitor (see sample display below). To return to the original screen, press the Back Button again.

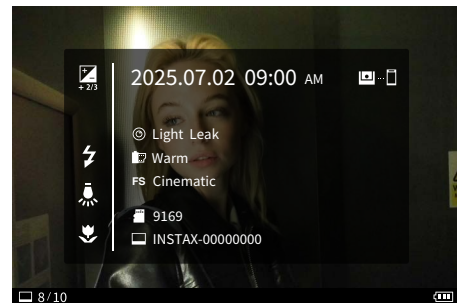

When a Memory Card is inserted,  is displayed on the information display screen.

Basic Operations – Shooting/Playback/Print

Printing Images

Before you print images, image rotation, zoom, image quality and brightness can be adjusted.

1 Press the Play Button.

The camera switches to the Playback Mode.

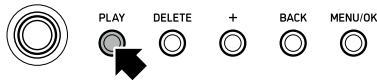

2 Move the Select Button to right or left to select the photo you want to print.



3 Rotate, zoom, adjust image quality/brightness as you prefer.

Press the Menu/Ok Button to display the setup menu. Move the Select Button up or down to select an item and press the Menu/Ok Button to enter.



For more information, see 'Various Playback – Direct Menu.' (p. 27)

4 Lift the lever on the Print Crank and rotate it in a clockwise direction to print.

The scale on the print gauge on the right side of the LCD Monitor rises with the movement of the Print Crank. When it reaches the top, printing begins.

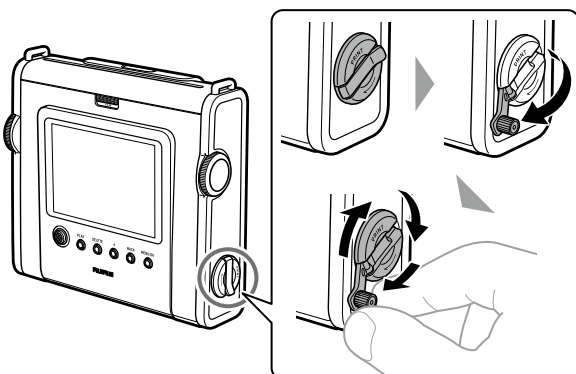

- If the Print Crank is turned counterclockwise before the scale reaches the top, the print can be cancelled.
- If the Print Crank is not turned until the scale has reached the top, the scale will go down.

5 When the sound of the film being ejected stops, grasp the edge of the ejected film and take the film out.

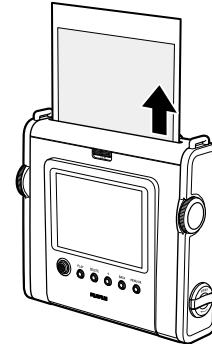

- The  mark is displayed on the images you have printed on the Playback screen.
- You can also print from the Direct menu.

• Be careful not to let your fingers or the Shoulder Strap get caught in the Film Ejection Slot.

- Paired with the free instax WIDE Evo™ Smartphone App, you can transfer your printed images to your Smartphone and add various frames. For more information, visit the instax™ website: https://instax.com/wide_evo/

Removing the instax™ WIDE Instant Film Pack

1 Slide the Film Door Lock and open the Film Door.

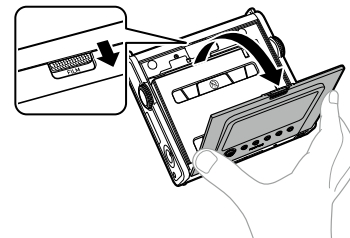

2 Grasp the rectangular holes on the film pack, then pull the film pack out from the camera.

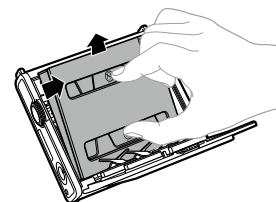

Stored Images

Storage Location

The location where your images get saved depends on whether a Micro SD Memory Card (sold separately) is inserted or not.

When Micro SD Memory Card is Not Inserted

If you shoot without inserting a Micro SD Memory Card, the shooting data will be saved in the camera's internal memory.

- An internal storage limitation of roughly 45 images applies unless a Micro SD Memory Card is inserted.

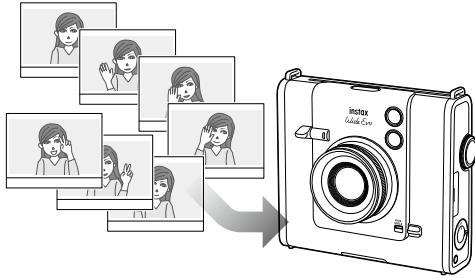

When Micro SD Memory Card is Inserted

When a Micro SD Memory Card is inserted, data is saved to the Micro SD Memory Card and not saved to the camera's internal memory.

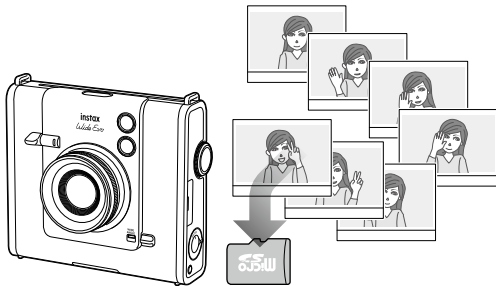

- Images stored in the camera's internal memory or Micro SD Memory Card do not automatically get deleted when you take photos. When the camera's internal memory or the memory on the Micro SD Memory Card is full, delete images to create more space.

Maximum Number of Images/Resolution

The resolution and the number of images that can be saved in either the internal memory or on a Micro SD Memory Card are shown below.

Number of possible images

	Internal memory	When Micro SD Memory Card is inserted
Images not in Wide-Angle Mode	2560 × 1920 pixels Approximately 45 images	2560 × 1920 pixels Approximately 850 images per 1 GB
Images in Wide-Angle Mode		4608 × 3456 pixels Approximately 280 images per 1 GB

Advanced Operation – Shooting

Various Shots – Direct Menu

Press the Menu/Ok Button on the Shooting screen to display the Direct menu to change the following shooting methods.

Changing the Brightness of the Image

Adjust the brightness of the image. Use this function when the subject is too bright or too dark, or when the contrast (difference between light and dark) between the subject and the background is too high.

- 1 Move the Select Button up or down to select [EXPOSURE].

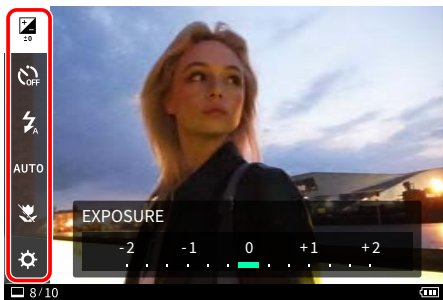

- 2 Move the Select Button left or right to correct the exposure.
 - Move the Select Button right to adjust the exposure to the + side to brighten the entire image.
 - Move the Select Button left to adjust the exposure to the - side to darken the entire image.
- 3 Press the Shutter Lever all the way down.

Using the Self Timer to Take Photos

Use this function to take a group photo including the photographer or to prevent the camera from moving while the Shutter Lever is pressed.

- 1 Move the Select Button up or down to select [SELF-TIMER].

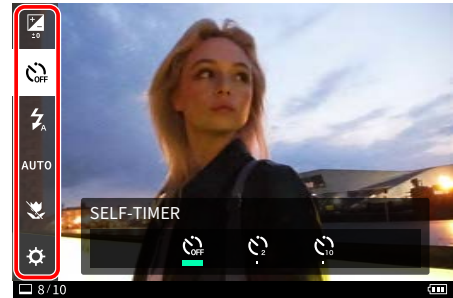

- 2 Move the Select Button left or right to select [2] or [10].

You can set a self timer for either 2 seconds or 10 seconds before the photo is taken.

 - If you do not want to set a self timer, select [OFF].
- 3 Press the Shutter Lever all the way down.

The countdown starts.

When [2] is selected:
When you press the Shutter Lever, the self timer lamp flashes.

When [10] is selected:
When you press the Shutter Lever, the self timer lamp lights up and starts flashing two seconds before taking the photo.

To cancel the self timer halfway through, press the Back Button.

Advanced Operation – Shooting

Taking Photos with the Flash

Use the Flash when taking photos at night or in a dark room. You can also set the camera so that the Flash does not fire.

- 1 Move the Select Button up or down to select [⚡].

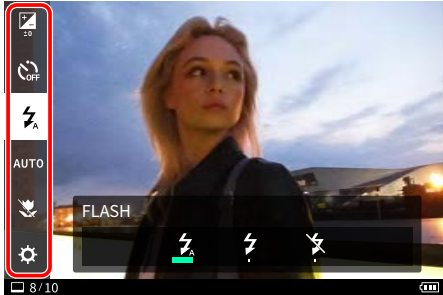

- 2 Move the Select Button left or right to select the Flash setting.
 - For more information on Flash settings, see “Types of Flash” below.
- 3 Press the Shutter Lever all the way down.
The flash fires when a photo is taken.

■ Types of Flash

⚡ AUTO FLASH

The Flash will fire automatically when the surroundings are dark. This setting applies to most situations.

⚡ FORCED FLASH

The Flash will fire regardless of the brightness of the surroundings. Use this setting when the subject is dark due to backlighting.

⚡ SUPPRESSED FLASH

The Flash will not fire even if the surroundings are dark. This setting is suitable for shooting in places where flash photography is prohibited.

When shooting in dark places without using the Flash, it is recommended to steady the camera on a table or similar surface.

Matching the Light Source When Taking Photos

By setting the white balance to match the light source, such as sunlight or artificial lighting, you can shoot with colors closer to real life.

- 1 Move the Select Button up or down to select [AUTO].

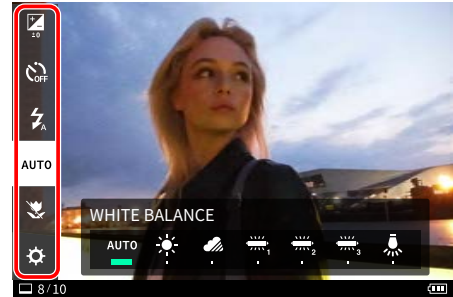

- 2 Move the Select Button left or right to select one of the settings.
 - For details on setting the white balance, see “Types of White Balance” below.
- 3 Press the Shutter Lever all the way down.

■ Types of White Balance

AUTO AUTO

The camera sets the white balance automatically. AUTO is recommended for normal shooting.

☀ FINE

For outdoor shooting in fine weather.

☁ SHADE

For shooting on cloudy days or in the shade.

💡₁ FLUORESCENT LIGHT-1

The brightest bluish white setting, such as in an office.

💡₂ FLUORESCENT LIGHT-2

Natural white setting close to sunlight.

💡₃ FLUORESCENT LIGHT-3

Warmer and more yellowish-white than the FLUORESCENT LIGHT-2 setting.

💡 INCANDESCENT

For shooting under light bulbs and incandescent lamps.

Advanced Operation – Shooting

Taking Macro Photos

Use Macro shooting when you want to get close to the subject.

- 1 Move the Select Button up or down to select [🌿].

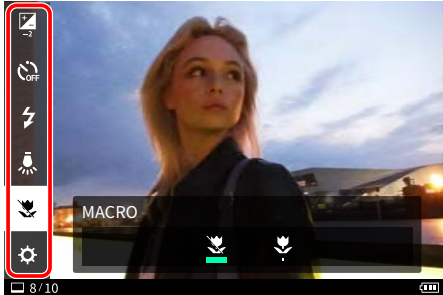

- 2 Move the Select Button left or right to select [🌿].
- 3 Press the Shutter Lever all the way down. Macro shooting is performed.

To cancel the Macro Mode, select [🌿].

Easy Focusing

Use the Settings menu to change the face detection and AF illuminator settings.

- 1 Press the Menu/Ok Button.

The Direct menu appears.

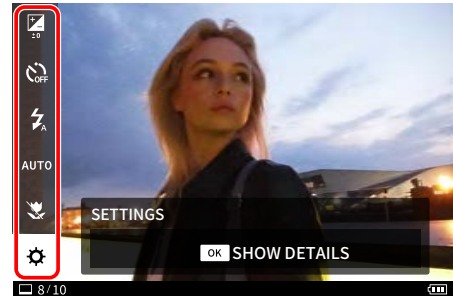

- 2 Move the Select Button up or down to select [⚙️], and then press the Menu/Ok Button.

The Settings menu is displayed.

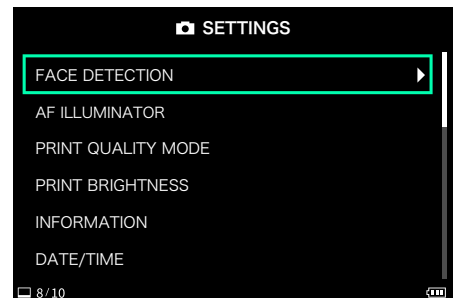

- 3 Move the Select Button up or down to select the item you want to set up.

• For details on each item, see following 'Settings Menu Items' below.

- 4 Change settings.

- 5 Press the Menu/Ok Button.

The settings are applied and the camera returns to the Shooting screen.

Settings Menu Items

FACE DETECTION

When [FACE DETECTION] is turned on, the camera detects the person's face and adjusts the focus and brightness to the face instead of the background to make the person stand out brightly.

AF ILLUMINATOR

When set to ON, the AF ILLUMINATOR lights from the time the Shutter Lever is pressed halfway until the subject is in focus, making it easy to focus on a dark subject.

- Depending on the scene, it may be difficult to get the subject in focus even when the AF ILLUMINATOR is activated.
- The AF ILLUMINATOR may not be fully effective when shooting close to the subject.
- Do not flash the AF ILLUMINATOR close to the human eye.

Photography with Effects

Adding Effects to Your Photos

The camera offers three effects: 10 lens effects, 10 film effects and 6 film styles to apply to your images.

You can also press the + (Function) Button to use your saved lens effect, film effect and film style combinations.

Selecting Lens Effects

Follow the steps below to select the type of lens effect to apply.

- 1 Display the Shooting screen.
- 2 Rotate the Lens Dial to select the type of lens effect.

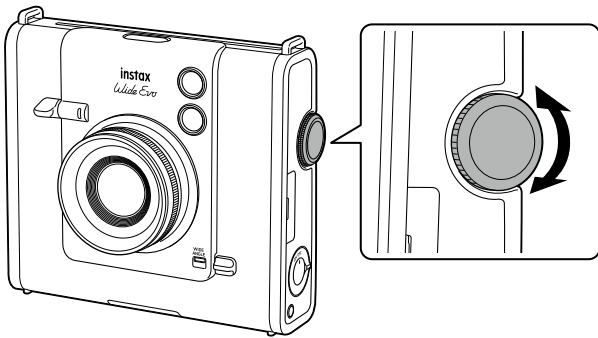

The selected lens effect appears on the left of the screen.

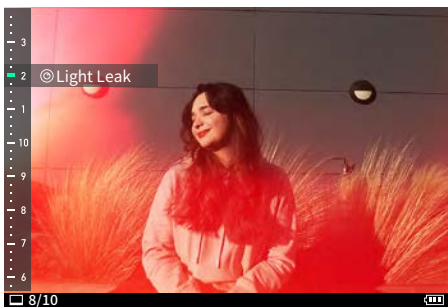

- To cancel the set lens effect, select [Normal] from the lens effect types.
- Press the Effect Reset Button to cancel the set lens effect, film effect and film style.

Adjusting the Degree of Lens Effect

You can adjust degree of the lens effect (making the selected lens effect appear brighter or more intense).

- 1 Display the Shooting screen.
- 2 Rotate the Lens Dial to select the type of lens effect.
- 3 Turn the Degree Control Dial to adjust the degree of the lens effect.

Set the desired degree while watching the screen.

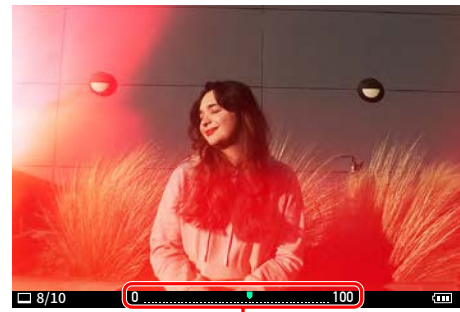

Degree adjustment level

Photography with Effects

Selecting a Film Effect

Follow the steps below to select the type of film effect.

- 1 Display the Shooting screen.
- 2 Turn the Film Dial to select the type of film effect.

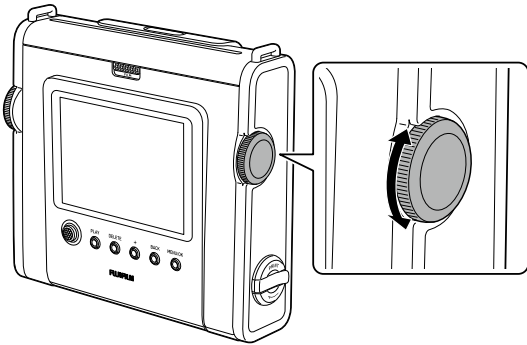

The selected film effect appears on the right of the screen.



- To cancel the set film effect, select [Normal] from the film effect types.
- Press the Effect Reset Button to cancel the set lens effect, film effect and film style.

Selecting a Film Style

Follow the steps below to select the type of film style.

- 1 Display the Shooting screen.
- 2 Press the Film Style Button repeatedly to select the type of film style.

When a film style is selected, the LED on the Film Style Button lights up. (When [Film Style LED] in the Settings menu is set to [ON])

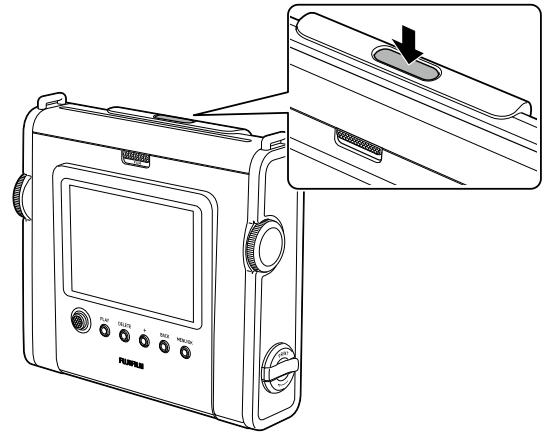

The following guide appears.

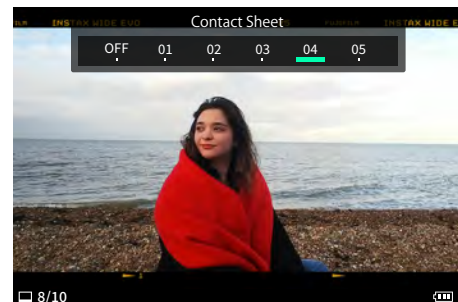

- To cancel the set film style, select [OFF] from the film style types.
- Press the Effect Reset Button to cancel the set lens effect, film effect and film style.

Photography with Effects

Effect Combinations

You can save a combination of your favorite effects. You can use a saved effect combination by pressing the + (Function) Button.

Saving an Effect Combination

- 1 Display the Shooting screen.
- 2 Rotate the Lens Dial to select the type of lens effect.
- 3 Rotate the Film Dial to select the type of film effect.
- 4 Press the Film Style Button repeatedly to select the type of film style.
- 5 Press the + (Function) Button.
- 6 Press the Menu/Ok Button.
- 7 Move the Select Button up or down to select [Favorite[1]] to [Favorite[10]].

Up to ten effect combinations can be saved.

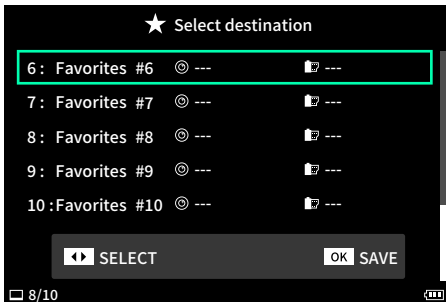

- 8 Press the Menu/Ok Button.
The effect combination is saved.

Using your Saved Effect Combinations

- 1 Display the Shooting screen.
- 2 Press the + (Function) Button twice.
- 3 Move the Select Button left or right to select [Favorite[1]] to [Favorite[10]].
The effect is applied.

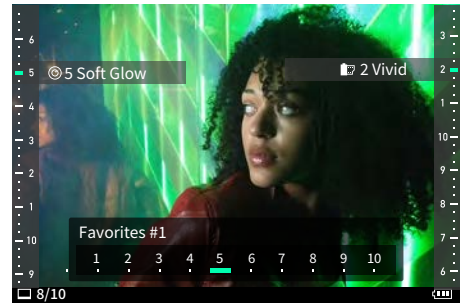

Photography with Effects

Reset Lens Effects, Film Effects and Film Styles

Reset the lens effect, film effect and film style settings to normal.

- 1 Press the Effect Reset Button.**

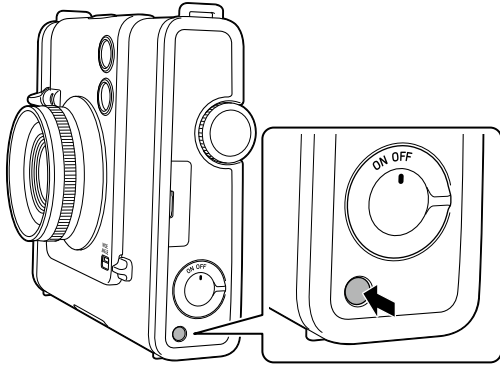

- 2 Press the Menu/Ok Button.**
The adjusted effect and style are reset.

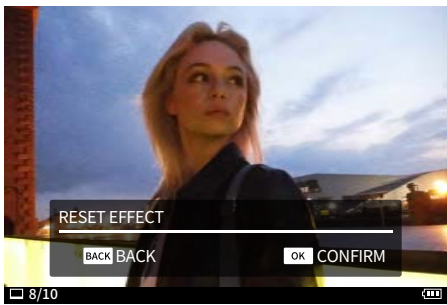

Image Adjustment During Playback and Printing

Various Playback – Direct Menu

Press the Menu/Ok Button on the Playback screen to display the Direct menu to change the following playback/print methods. For information on how to display the Playback screen, see page 16.

Rotating and Adjusting the Position of the Image

- 1 Move the Select Button left or right to choose the photo you want to view.
- 2 Press the Menu/Ok Button.
The Direct menu appears.
- 3 Move the Select Button up or down to select [↻].

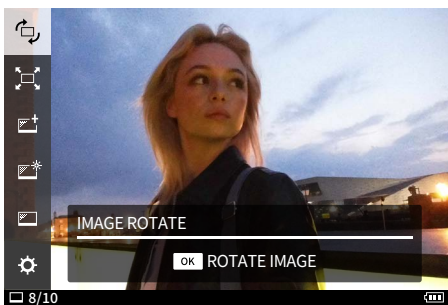

- 4 Press the Menu/Ok Button.
The image rotate guide appears.

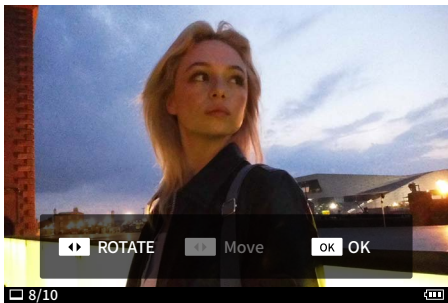

- 5 Move the Select Button left or right to select image orientation.
- 6 Move the Select Button up or down to adjust image position.
 - Enlarged images cannot be repositioned.
- 7 Press the Menu/Ok Button.
The adjusted image is displayed.

Enlarging the Image

You can enlarge images.

- 1 Move the Select Button left or right to choose the photo you want to view.
- 2 Press the Menu/Ok Button.
The Direct menu appears.
- 3 Move the Select Button up or down to select [📐].

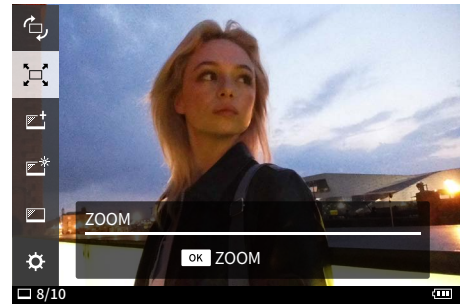

- 4 Press the Menu/Ok Button.
The zoom/move guide appears.

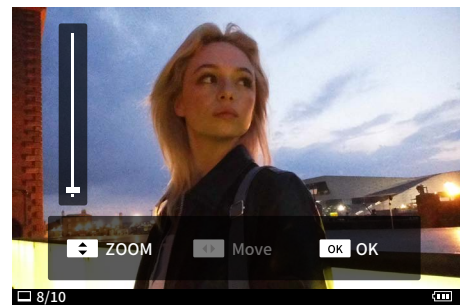

- 5 Move the Select Button up or down to adjust the size of the image.
- 6 Move the Select Button left or right to adjust the position of the image.
- 7 Press the Menu/Ok Button.
The adjusted image is displayed.

Image Adjustment During Playback and Printing

Selecting Image Quality

You can select the image quality when printing.

- 1 Move the Select Button left or right to choose the photo you want to view.**
- 2 Press the Menu/Ok Button.**
The Direct menu appears.
- 3 Move the Select Button up or down to select [Print].**

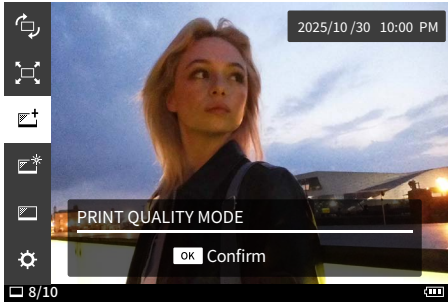

- 4 Press the Menu/Ok Button.**
The print quality mode guide appears.
- 5 Move the Select Button up or down to select the print quality mode.**
Set to [instax-Natural Mode] for natural color quality, or [instax-Rich Mode] for a rich color representation (factory default).
- 6 Press the Menu/Ok Button.**
The original screen is displayed.

Adjusting the Brightness of the Printed Image

You can adjust the brightness of the image when printing.

- 1 Move the Select Button left or right to choose the photo you want to view.**
- 2 Press the Menu/Ok Button.**
The Direct menu appears.
- 3 Move the Select Button up or down to select [Print].**

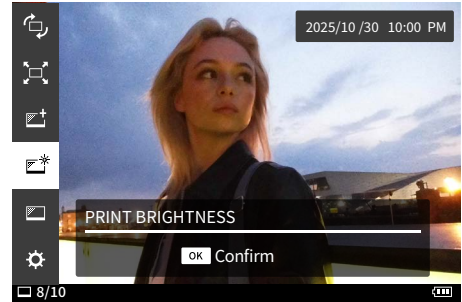

- 4 Press the Menu/Ok Button.**
The print brightness guide appears.
- 5 Move the Select Button up or down to select the print brightness.**
Set [x1 (standard)], [x1.5 (brighter)], or [x2.0 (brightest)].
- 6 Press the Menu/Ok Button.**
The original screen is displayed.

Settings Menu

Operations and Items in the Settings Menu

Various settings can be changed from the Settings menu.

1 Press the Menu/Ok Button.

The Direct menu appears.

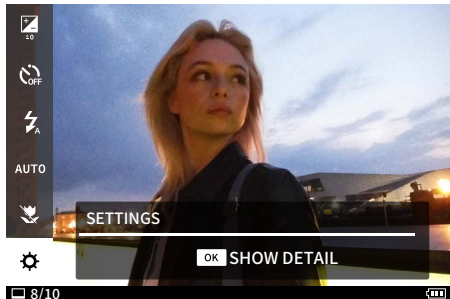

2 Move the Select Button up or down to select [⚙️], and then press the Menu/Ok Button.

The Settings menu is displayed according to the Shooting Mode or Playback Mode.

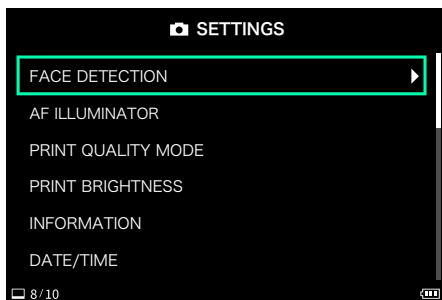

3 Move the Select Button up or down to select the item.

- For more information on each item, see the following 'Settings Menu Items in Shooting Mode' and 'Settings Menu Items in Playback Mode'.

4 Change settings.

5 Press the Menu/Ok Button.

The settings are applied and the camera returns to the original screen.

■ Settings Menu Items in Shooting Mode

FACE DETECTION

When [FACE DETECTION] is turned on, the camera detects the person's face and adjusts the focus and brightness to the face instead of the background to make the person stand out brightly.

AF ILLUMINATOR

When set to ON, the AF ILLUMINATOR lights from the time the Shutter Lever is pressed halfway until the subject is in focus, making it easy to focus on a dark subject.

PRINT QUALITY MODE

Set to [instax-Natural Mode] for natural color quality, or [instax-Rich Mode] for a rich color representation (factory default).

PRINT BRIGHTNESS

Set [$\times 1$ (standard)], [$\times 1.5$ (brighter)], or [$\times 2.0$ (brightest)].

INFORMATION

Displays the serial number of the camera.

DATE/TIME

Sets the date and time.

言語/LANG.

Sets the language displayed on the LCD Monitor.

SOUND SET-UP

Sets the volume of the operation sound, shutter volume, and start-up sound.

If you want to turn off the sound, set this to [OFF].

AUTO PICTURE TRANSFER

Sets whether printed images are automatically transferred to the free instax WIDE Evo™ Smartphone App.

AUTO POWER OFF

Sets the time for the camera to turn off automatically when it has not operated for a period of time (5 seconds, 2 seconds or disable this feature).

FILM STYLE LED

When set to [ON], the LED on the Film Style Button lights up while a film style is selected.

RESET

Resets the settings to the factory default values. The date and time set in DATE/TIME will not be reset.

FORMAT

Initializes the camera's internal memory or a Micro SD Memory Card inserted in the Micro SD Memory Card Slot. All stored images will be deleted.

FIRMWARE UPGRADE

Upgrades the firmware.

For upgrade details, see 'Upgrading the Firmware.' (p. 30)

■ Settings Menu Items in Playback Mode

TRANSFER IMAGE

You can transfer images printed with the camera to the free instax WIDE Evo™ Smartphone App and save them as framed instax™ WIDE images on your Smartphone.

COPY

Copies images from the internal memory to the Micro SD Memory Card or from the Micro SD Memory Card to the internal memory. Follow the steps below.

1. Select [COPY] from the Settings menu.
2. Select the source and destination of copying and press the Menu/Ok Button.
3. Select [FRAME], [MULTIPLE FRAMES] or [ALL FRAMES] and press the Menu/Ok Button.
If you select [FRAME], copying starts.
If you select [ALL FRAMES], press the Menu/Ok Button to start copying.
When [MULTIPLE FRAMES] is selected, move the Select Button up, down, left or right to select the image to be copied and press the + (Function) Button to start copying.

Settings Menu

DELETE ALL IMAGES

Deletes all images in the internal memory or Micro SD Memory Card inserted in the Micro SD Memory Card Slot at once.

INFORMATION

Displays the serial number of the camera.

DATE/TIME

Sets the date and time.

言語/LANG.

Sets the language displayed on the LCD Monitor.

SOUND SET-UP

Sets the volume of the operation sound, shutter volume, and start-up sound.

If you want to turn off the sound, set this to [OFF].

AUTO PICTURE TRANSFER

Sets whether printed images are automatically transferred to the free instax WIDE Evo™ Smartphone App.

AUTO POWER OFF

Sets the time for the camera to turn off automatically when it has not operated for a period of time (5 seconds, 2 seconds or disable this feature).

FILM STYLE LED

When set to [ON], the LED on the Film Style Button lights up while a film style is selected.

RESET

Resets the settings to the factory default values.
The date and time set in DATE/TIME will not be reset.

FORMAT

Initializes the camera's internal memory or a Micro SD Memory Card inserted in the Micro SD Memory Card Slot. All stored images will be deleted.

FIRMWARE UPGRADE

Upgrades the firmware.
For upgrade details, see 'Upgrading the Firmware' on this page.

■ Upgrading the Firmware

There are two ways to upgrade the firmware; when upgrading via PC, prepare a Micro SD Memory Card (sold separately) in advance.

● Using the free instax WIDE Evo™ Smartphone App

1. Launch the instax WIDE Evo™ Smartphone App.
2. Tap [Firmware update] in the Set-up menu.
3. Tap [OK].
4. Follow the on-screen instructions.

● Using the Camera

1. Download the latest firmware (FPUPDATE.DAT) from the specified website using a PC or other device, and copy it to the root directory of the Micro SD Memory Card.
2. Insert the Micro SD Memory Card with the copied firmware into the Micro SD Memory Card Slot of the camera.
3. Select [FIRMWARE UPGRADE] in the Settings menu.
4. Follow the on-screen instructions.

free instax WIDE Evo™ Smartphone App

Smartphone App Functions

The following functions are available when connected with the free instax WIDE Evo™ Smartphone App.

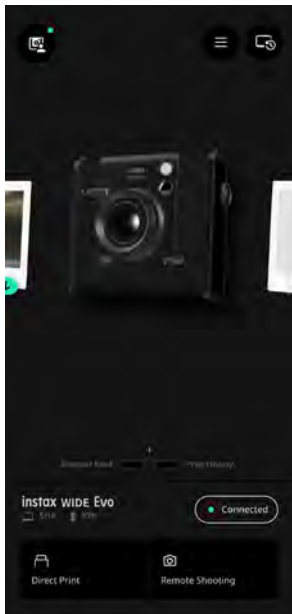

● Direct Print

Transfer a photo from your Smartphone to the camera, and print it with the camera using the instax™ Direct Print feature on the App. Before printing the photo, you can use the instax WIDE Evo™ App to rotate it, enlarge it or reduce its size.

● Remote Shooting

Control the camera with your Smartphone for remote shooting of photos.

● Save Printed Images

You can transfer photos you had printed with the camera to the instax WIDE Evo™ App. You can also add instax™ frames to your images and save them on your Smartphone.

● Discover Feed

The Discover Feed section in the App allows you to explore other users' images that were taken with the instax WIDE Evo™ hybrid instant camera in addition to displaying your own images. You can also check out the effects and settings that were used.

● Add to Favorites

You can easily save the film effect settings of works you have printed or that others have used (where such photos are posted on the Discover Feed) to your camera favorites for future use.

Installing the free instax WIDE Evo™ Smartphone App

Please install the free instax WIDE Evo™ Smartphone App before using the camera. After downloading is complete, you have to pair your Smartphone and the camera.

- If you are using an Android OS Smartphone, please search for the free instax WIDE Evo™ Smartphone App in Google Play Store and install it.

*Requirements for Android OS Smartphones: Android Ver. 10.0 or higher with Google Play Store installed

- If you are using an iOS Smartphone, please search for the free instax WIDE Evo™ Smartphone App in the App Store and install it.

*Requirements for iOS Smartphones: iOS Ver. 16.0 or higher

- Depending on your Smartphone model, you may not be able to use the free instax WIDE Evo™ Smartphone App even if you have installed it and your Smartphone meets the above requirements.

Visit the free instax WIDE Evo™ Smartphone App download site for the latest information on system requirements.

- Scan to download the free instax WIDE Evo™ Smartphone App



iOS



Android OS

The text QR code itself is a registered trademark and wordmark of Denso Wave Incorporated.

- 1 Open the free instax WIDE Evo™ Smartphone App.
- 2 Read the terms of use, and tap [Agree].
- 3 Select your region then tap [OK].
If you are using the camera in Europe, select [Europe].
- 4 Tap [Next].
- 5 Read the privacy policy, check [Agree and allow log collection], and tap [Next].
- 6 Tap [Go to Bluetooth connection settings].
- 7 Tap [ALLOW].
- 8 When the camera is detected, tap [Connect].
If multiple cameras are detected, select the camera to connect from the list.
The camera's identifier (device name) is located on the bottom of the camera.
- 9 Enter the serial number of the camera, and tap [Connect].
- 10 Tap [Next].
- 11 A quick-start guide is displayed. Read the instructions and tap [Next].

When Disposing of the Camera

Removing the Battery at End of Life

Dispose of the battery according to the instructions of your local recycling department and local government.

- 1 Remove the bottom cover using a screwdriver (sold separately).**

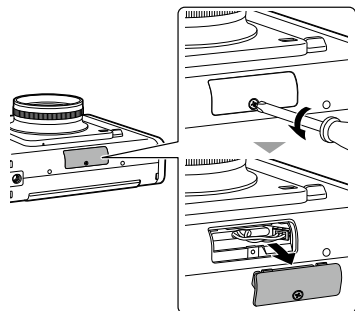

- 2 Pull out the wiring, remove the connector, and pull the battery out.**

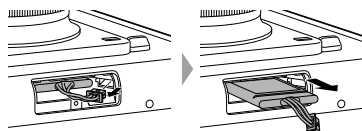

Other Information

Specifications

■ Camera Function

Image sensor	1/3-inch CMOS with primary color filter
Number of recorded pixels	<ul style="list-style-type: none"> • 4608 × 3456 (Wide Angle Switch ON & Micro SD Memory Card inserted) • 2560 × 1920 (Others)
Storage media	Internal memory, Micro SD / Micro SDHC Memory Card (sold separately)
Storage capacity	Approximately 45 images in internal memory, Wide Angle Switch ON: approximately 280 images Wide Angle Switch OFF: approximately 850 images per 1 GB in Micro SD/Micro SDHC Memory Card
Recording method	DCF compliant Exif Ver 2.3
Focus distance	f = 16 mm (35 mm film equivalent)
Aperture	F2.4
Auto focus	Single AF, Face recognition AF (on/off) (with auxiliary light)
Shooting distance	3.9 in. (10 cm) and beyond
Shutter speed	1/4 second to 1/8000 second (automatic switching)
Shooting sensitivity	ISO100 to 1600 (automatic switching)
Exposure control	Program AE
Exposure compensation	-2.0 EV to +2.0 EV (1/3 EV step)
Metering method	TTL 256 split metering, multi metering
White balance	Auto, Fine, Shade, Fluorescent 1, Fluorescent 2, Fluorescent 3, Incandescent
Flash	AUTO FLASH/FORCED FLASH/SUPPRESSED FLASH Shooting range with flash: Approximately 11.8 in. (30 cm) to 59 in. (1.5 m)
Self timer	2 settings: Approximately 2 seconds / approximately 10 seconds
Image effects	10 lens effects with degree control functions, 10 film effects, and 6 film styles

■ Print function

Exposure pixel count	1600 × 1260 dots (800 × 1260 dots when printed from free instax WIDE Evo™ Smartphone App)
----------------------	--

Exposure resolution	25 dots/mm × 12.5 dots/mm (635 × 318 dpi, 40 × 80 μm dot pitch) 12.5 dots/mm when printed from Smartphone App (318 dpi, 80 μm dot pitch)
Exposure gradation	RGB gradation of 256 colors
Interface	Standard compliance: Bluetooth Ver. 5.1
Printable image format	From the camera's internal memory or Micro SD / MicroSDHC Memory Card: JPEG images taken with this camera From a Smartphone: JPEG, PNG, HEIF
Print output time	Approximately 16 seconds
Print function	Images in the internal memory and images in the Micro SD Memory Card (sold separately) can be printed

■ Other

Smartphone app functions	Smartphone image print function, remote shooting function, printed image transfer function, firmware upgrade function
LCD Monitor	3.5-inch TFT color LCD Monitor Pixel count: Approximately 460,000 dots
External interface	USB Type C port (for charging only)
Power supply	Lithium ion battery (internal type)
Possible number of printed images	Approximately 100 (from full charge) The number of prints depends on the usage conditions.
Charging time	Approximately 2 - 3 hours Charging time depends on the temperature.
Main unit dimensions	5.46 in. x 4.92 in. x 2.47 in. / 138.7 mm × 125 mm × 62.8 mm (excluding projecting parts)
Main unit weight	Approximately 1.08 lbs (490 g) (instax™ WIDE film pack, recording media, and lens cap not included.)
Operating environment	Temperature: 41°F to 104°F (5°C to 40°C) Humidity: 20% to 80% (no condensation)
Instant film used	FUJIFILM instax™ WIDE instant film (sold separately)

*The above specifications are subject to change for better performance.

Other Information

Troubleshooting

Please check the following items before considering a problem to be a malfunction. If the problem persists even after taking action, please contact the FUJIFILM service center for repair in your country or visit the website below:

FUJIFILM website: <https://www.fujifilm.com/>

If the following problem occurs...

Problem	Possible causes and solutions
I cannot turn on the camera.	The battery may not be charged. Please charge the camera.
The battery loses its charge quickly.	If you use the camera in a very cold environment, the battery will drain quickly. Move the camera to a warmer environment and allow it to adjust to room temperature before using the camera.
Camera shuts down during use.	The battery level may be low. Please charge the camera.
Charging does not start.	<ul style="list-style-type: none"> • Make sure that the USB power adapter plug is properly connected to the power outlet. • Turn off the camera when charging it. If power is on camera will not charge.
It takes too long to charge.	At low temperatures, charging may take longer.
The self timer lamp flashes while charging.	Charge the battery in a temperature range of +41°F (+5°C) to +104°F (+40°C). If you cannot charge the battery within this range, please contact our support center.
I am unable to shoot when I press the Shutter Lever.	<ul style="list-style-type: none"> • Make sure that the power is on. • If the battery level is low, please charge the camera. • If the internal memory or Micro SD Memory Card is full, insert a new Micro SD Memory Card or delete unnecessary images. • Use a Micro SD Memory Card formatted with this unit. • If the contact surface of the Micro SD Memory Card (gold part) is dirty, wipe it with a soft, dry cloth. • The Micro SD Memory Card may be broken. Please insert a new Micro SD Memory Card.
I am unable to focus the camera.	Use the AF/AE lock to shoot subjects that are difficult to focus on.
The Flash does not fire.	Check that the suppressed Flash setting has not been selected. Select a setting other than the suppressed Flash setting.

Problem	Possible causes and solutions
Even though the Flash fired, the image is dark.	<ul style="list-style-type: none"> • Check to see if you are far from the subject. Shoot within the range where photography is possible: Approximately 11.8 in. (30 cm) to 59 in. (1.5 m). • Hold the camera correctly so that you do not obstruct the Flash with your fingers.
The image is blurry.	<ul style="list-style-type: none"> • Check to see if the lens has any fingerprints. If so, clean the lens. • Make sure that the AF frame is green before taking a photo. • Make sure to hold the camera steady, particularly in dark environments.
The camera does not work properly.	<ul style="list-style-type: none"> • There may be a temporary malfunction. Please press the Reset Button. If it still does not work properly, please contact our repair service center for repair. • The battery may not be charged. Charge the camera.
The film pack does not load or does not load smoothly.	<ul style="list-style-type: none"> • Please use only FUJIFILM instax WIDE™ instant film (instax™ SQUARE or instax™ mini instant film can not be used). • Align the yellow mark on the film pack with the yellow alignment mark on the camera body to load the film.
The film does not unload.	<ul style="list-style-type: none"> • The film may be misaligned due to shock such as vibration or dropping. Please load a new film pack. • If the film is jammed, turn off the camera and turn it on again. If the problem persists, remove the jammed film and then load a new film pack.
Some or all of the finished prints are white.	Do not open the Film Door until the film is used up. If the Film Door is opened with film remaining, the film is exposed and the exposed area becomes white.
The print is uneven.	<ul style="list-style-type: none"> • Do not shake, bend, fold or hold the print immediately after it is printed. • Do not obstruct the Film Ejection Slot.
The camera is malfunctioning and cannot be turned off.	Press the Reset Button next to the Micro SD Memory Card Slot to turn off the power. (p. 5)

Other Information

IMPORTANT SAFETY NOTICE

This product has been designed with safety in mind and to also provide safe operation when handled correctly and in accordance with the instructions in this User's Guide. It is important that both the product and the instax™ WIDE instant film pack (sold separately) are handled properly and used only to print photos as instructed in the User's Guide and in the instax™ WIDE instant film pack (sold separately) instructions. For your ease and safety, strictly follow the instructions in this User's Guide.

WARNING

This symbol indicates danger, which could result in injury or death. Follow the instructions indicated to avoid damage to the camera or injury.

WARNING

 If one of the following cases occur, immediately unplug the supplied USB Type C cable, turn the camera off, refrain from any further use of the camera and call the applicable Fujifilm Customer Service Center:

- The camera becomes hot, emits smoke, has a burnt smell, or otherwise seems abnormal.

 The camera has a built-in battery. Do not subject it to heat, expose it to an open flame, drop it, or otherwise apply impact to it. Doing so may cause the camera to explode, resulting in injury.

WARNING

 Never attempt to take this product apart. You may be injured.

 Necessary repairs should be diagnosed and handled by Fujifilm. Injury may result from attempts to self-assess or self-repair this camera. Contact Fujifilm Customer Service to discuss repair issues.

 If this product is dropped or damaged so that the inside is showing, do not touch it. Call the applicable Fujifilm Customer Service Center.

 Do not touch any parts which are inside the Film door. You may be injured.

 Never get this product wet or handle it with wet hands. Doing so may result in an electric shock and injury.

 Promptly unplug the supplied USB Type C cable once the battery is fully charged. Camera should not over-charge.

 Keep out of the reach of small children. This product could cause injury in the hands of a child.

 Do not cover or wrap the camera or USB AC adapter (sold separately) in a cloth or blanket, or otherwise place the camera in the sun or an environment where heat may build up. This could distort the casing or cause a fire.

	The "CE" mark certifies that this product satisfies the requirements of the EU (European Union) regarding safety, public health, environment and consumer protection. ("CE" is the abbreviation of Conformité Européenne.)
--	--

Camera Care

■ Handling of Camera

1. Do not open the back camera cover until all 10 film sheets of the instax™ WIDE instant film pack (sold separately) have been used. Opening the Film door will expose any remaining, unused film sheets, rendering the remainder of the film pack unusable.
2. The camera is a precision instrument, so do not get it wet, drop it, or subject it to shock. Also do not place the camera where it will be exposed to sand, dirt or dust particles.
3. Do not use a strap made for cellular phones or other similar electronic products. These straps are usually too weak to hold your camera securely. For safety, only use the included Shoulder Strap designed for your camera, and use only as specifically intended and instructed.
4. Do not use solvent such as thinner or alcohol to remove dirt. Use a dry clean cloth.
5. Do not leave the camera in a closed motor vehicle, another hot place, a humid place, on the beach, etc. for a long period of time.
6. Gas containing moth repellent may adversely affect the camera and instax™ instant film. Avoid keeping the camera and instax™ instant film in a chest of drawers, etc. with mothballs.
7. The operating temperature range of this camera is 41°F (+5°C) to 104°F (+40°C).
8. When taking photos, please be careful not to violate the rights of others, such as copyright, image rights, and privacy, or violate public order. Any act that violates the rights of others, or is contrary to public order or morals, or constitutes a nuisance, is subject to legal penalties and claims for damages.
9. This camera is for general household use. It is not suitable for commercial photography and other applications where a large number of prints are needed.

■ Handling the LCD Monitor

As the LCD Monitor can be easily scratched or damaged by sharp or solid objects, we recommend you attach a protective sheet (sold separately) onto the monitor.

■ Charging the Battery

The battery is not charged at shipment. Charge the battery completely before use.

Charge the camera using the supplied USB Type C cable in a USB outlet, or attach the USB Type C cable to a USB AC adapter (adapter sold separately) and charge in an electric power outlet. Charging times will increase at ambient temperatures below 50°F (10°C) or above 95°F (35°C). Do not attempt to charge the battery in environments with temperatures above 104°F (40°C); at temperatures below 41°F (5°C), the battery will not charge.

■ Battery Life

At normal temperatures, the battery can be recharged about 300 times. A noticeable decrease in the length of time the battery will hold a charge indicates that it has reached the end of its service life.

■ Caution: Handling the Battery Compartment

The battery compartment and camera body may become warm to the touch after extended use. This is normal.

Other Information

■ Applicable certification disclosures are located inside the film chamber.

■ Cautions During Printing



Do not shake the camera while printing.



Do not drop the camera while printing.



Do not cover the Film Ejection Slot while printing.

■ instax™ WIDE Instant Film and Photo Care

This camera uses instax™ WIDE instant film, sold separately. See FUJIFILM instax™ WIDE instant film pack use instructions (sold separately). Follow all instructions for safe and proper use, including:

1. Keep the film pack in a cool place. Do not leave the film pack in a place where the temperature is extremely high (e.g., in a closed car) for many hours.
2. Do not puncture, tear, or cut instax™ WIDE instant film. If film becomes damaged, do not use.
3. When you load a film pack, use the film as soon as possible.
4. If the film pack or camera has been kept in a place where the temperature is extremely high or low, bring it to room temperature before starting to print photos.
5. Be sure to use the film pack before the expiration or "Use Before" date.
6. Avoid airport checked luggage inspection and other strong X-ray illumination. Such exposure may cause fogging and otherwise affect your unused film. Carrying your camera and film onto an aircraft in your carry-on is recommended. (Check with each airport for more information.)
7. Avoid exposing the developed instant photos to strong light, and keep them in a cool, dry place.
8. ⚠ CAUTION: Do not puncture or cut your instax™ photo as it contains a small amount of caustic paste (high alkaline). Never let children or animals put an instax™ instant photo into their mouth. Also pay attention so that the paste does not come into contact with skin or clothes.
9. ⚠ CAUTION: In case the paste inside the film comes into contact with skin or clothes, immediately wash off with plenty of water. If the paste comes into contact with the eyes or mouth, immediately wash the area with plenty of water and contact a doctor. Note that the alkaline inside the film remains active for about 10 minutes after the photo has been printed.
10. Do not store photos in a sealed bag, as this may cause discoloration.
11. Do not touch the photo during development time.

■ Cautions on Handling of instax™ WIDE Instant Film and Finished Photos

For details, see the instructions on the instax™ WIDE instant film packaging (sold separately).



Bluetooth® Devices: Cautions

IMPORTANT: Read the following notices before using the product's built-in Bluetooth transmitter.

■ Use only as part of a Bluetooth network.

FUJIFILM does not accept liability for damages resulting from unauthorized use. Do not use in applications requiring a high degree of reliability, for example in medical devices or other systems that may directly or indirectly impact human life. When using the device in computer and other systems that demand a greater degree of reliability than Bluetooth networks, be sure to take all necessary precautions to ensure safety and prevent malfunction.

■ Use only in the country in which the device was purchased.

This device conforms to regulations governing Bluetooth devices in the country in which it was purchased. Observe all location regulations when using the device. FUJIFILM does not accept liability for problems arising from use in other jurisdictions.

■ Wireless data (images) may be intercepted by third parties.

The security of data transmitted over wireless networks is not guaranteed.

■ Do not use the device in locations subject to magnetic fields, static electricity, or radio interference.

Do not use the transmitter in the vicinity of microwave ovens or in other locations subject to magnetic fields, static electricity, or radio interference that may prevent reception of wireless signals. Mutual interference may occur when the transmitter is used in the vicinity of other wireless devices operating in the 2.4 GHz band.

Other Information

■ **The Bluetooth transmitter operates in the 2.4 GHz band. The maximum radio-frequency power is 6.93 mW.**

■ **This device operates on the same frequency as commercial, educational, and medical devices and wireless transmitters.**

It also operates on the same frequency as licensed transmitters and special unlicensed low-voltage transmitters used in radio-frequency identification tracking systems for assembly lines and in other similar applications.

■ **To prevent interference with the above devices, observe the following precautions.**

Confirm that the radio-frequency identification transmitter is not in operation before using this device. If you notice that this device causes interference in low-voltage radio-frequency identification tracing systems, contact a FUJIFILM representative.

■ **The following may be punishable by law:**

- Disassembly or modification of this device (except in connection with proper battery disposal).
- Removal of device certification labels.

For customers in the USA:

FCC ID : W2Z-0300013

FCC Statement

This device complies with part 15 of the FCC Rules. Operation is subject to the following two conditions: (1) This device may not cause harmful interference, and (2) this device must accept any interference received, including interference that may cause undesired operation.

For more information, access the website below.

https://instax.com/support/declaration/#wide_evo

CAUTION

This equipment has been tested and found to comply with the limits for a Class B digital device, pursuant to Part 15 of the FCC Rules. These limits are designed to provide reasonable protection against harmful interference in a residential installation. This equipment generates, uses, and can radiate radio frequency energy and, if not installed and used in accordance with the instructions, may cause harmful interference to radio communications. However, there is no guarantee that interference will not occur in a particular installation. If this equipment does cause harmful interference to radio or television, which can be determined by turning the equipment off and on, the user is encouraged to try to correct the interference by one or more of the following measures:

- Reorient or relocate the receiving antenna.
- Increase the separation between the equipment and receiver.
- Connect the equipment into an outlet on a circuit different from that to which the receiver is connected.
- Consult the dealer or an experienced radio/TV technician for help.

Changes or modifications not expressly approved by FUJIFILM responsible for compliance could void the user's authority to operate the equipment.

This transmitter must not be co-located or operated in conjunction with any other antenna or transmitter.

The available scientific evidence does not show that any health problems are associated with using low power wireless devices. There is no proof, however, that these low power wireless devices are absolutely safe. Low power wireless devices emit low levels of radio frequency energy (RF) in the microwave range while being used. Whereas high levels of RF can produce health effects (by heating tissue), exposure of low-level RF that does not produce heating effects causes no known adverse health effects.

Many studies of low-level RF exposures have not found any biological effects. Some studies have suggested that some biological effects might occur, but such findings have not been confirmed by additional research. This device has been tested and found to comply with FCC radiation exposure limits set forth for an uncontrolled environment and meets the FCC radio frequency (RF) Exposure Guidelines.

Notes on the Grant

To comply with Part 15 of the FCC Rules, this product must be used with a FUJIFILM-specified dedicated charging cable.

Other Information

For customers in Canada:

IC : 7736B-03000012

ISED statement:

This device complies with Innovation, Science and Economic Development Canada's licence-exempt RSS(s). Operation is subject to the following two conditions:

- (1) This device may not cause interference, and
- (2) This device must accept any interference, including interference that may cause undesired operation of the device.

CAN ICES-003(B) / NMB-003 (B)

This device contains licence-exempt transmitter(s)/receiver(s) that comply with Innovation, Science and Economic Development Canada's licence-exempt RSS(s). Operation is subject to the following two conditions:

1. This device may not cause interference.
2. This device must accept any interference, including interference that may cause undesired operation of the device.

The available scientific evidence does not show that any health problems are associated with using low power wireless devices. There is no proof, however, that these low power wireless devices are absolutely safe. Low power wireless devices emit low levels of radio frequency energy (RF) in the microwave range while being used. Whereas high levels of RF can produce health effects (by heating tissue), exposure of low-level RF that does not produce heating effects causes no known adverse health effects. Many studies of low-level RF exposures have not found any biological effects. Some studies have suggested that some biological effects might occur, but such findings have not been confirmed by additional research. This device has been tested and found to comply with ISED radiation exposure limits set forth for an uncontrolled environment and meets RSS-102 of the ISED radio frequency (RF) exposure rules.

Proper Disposal of Camera – US, Canada and Latin America



Disposal of Electric and Electronic Equipment in Private Households
Disposal of used Electrical & Electronic Equipment (Applicable in the European Union and other European countries with separate collection systems)

This symbol on the product, the full version of the User's Guide, Quick Start Guide, in the limited product warranty, and/or on its packaging indicates that this product shall not be treated as household waste.

Instead it should be taken to an applicable collection point for the recycling of electrical and electronic equipment.

By ensuring this product is disposed of correctly, you will help prevent potential negative consequences to the environment and human health, which could otherwise be caused by inappropriate waste handling of this product.

The recycling of materials may help to conserve natural resources.

For more detailed information about recycling of this product, please contact your local city recycling office, your household waste disposal service or the authorized FUJIFILM dealer from which you purchased the product.

For proper disposal in the United States at product end-of-life, please contact 1-800-800-3854 Option #1 INSTAX.

For proper disposal in Canada at product-end-of-life, please contact 1-800-461-0416.

For proper disposal in Latin America at product end-of-life, please contact your local FUJIFILM distributor or dealer for disposal instructions.

Other Information

Information for FUJIFILM in the United States

FUJIFILM North America Corp.
200 Summit Lake Drive
Valhalla, New York 10595, USA
1-800-800-3854 Option #1 INSTAX

Information for FUJIFILM in Canada

FUJIFILM Canada Inc.
600 Suffolk Court,
Mississauga, Ontario L5R 4G4, Canada
1-800-461-0416

If you have any inquiries about this product, please contact the applicable Fujifilm Customer Service/Repair Center, or access the website below.

<https://www.fujifilm.com/>

The Bluetooth® word mark and logos are registered trademarks owned by Bluetooth SIG, Inc., and any use of such marks by Fujifilm is under license.

Independent JPEG Group (IJG) Licenses

This software is based in part on the work of the Independent JPEG Group.

FUJIFILM, instax, instax mini, instax SQUARE, instax WIDE and instax WIDE Evo are trademarks of FUJIFILM Corporation and its affiliates.

© 2025 FUJIFILM Corporation. All rights reserved.

FUJIFILM

FUJIFILM Corporation

7-3, AKASAKA 9-CHOME, MINATO-KU, TOKYO 107-0052, JAPAN